



RE 250 Variable Area Flowmeter

Operating Instruction

All rights reserved. It is prohibited to reproduce this document, or any parts thereof, without prior written authorization of MECON GmbH.

Subject to change without notice.

Copyright 2018 by
MECON GmbH - Röntgenstraße 105 - 50169 Kerpen - Germany

Contents

1 Safety instructions	4
1.1 Intended use	4
1.2 Certifications	5
1.3 Safety instructions from the manufacturer	5
2 Start-up	6
3.1 Standard device	6
3.2 Device with electrical output (MEM)	7
3.3 Device with limit switches	7
3 Installation mode of operation	8
2.1 Notes on installation	8
2.2 Installation	8
2.3 Operating principle	10
2.4 Classification according the Pressure Equipment Directive 2014/68/EU	10
4 Service	11
4.1 Storage	11
4.2 Maintenance and cleaning	11
4.3 Replacing float	12
4.4 Replacing float damping	12
4.5 Returning the device to the manufacturer	13
5 Device description	14
5.1 Scope of delivery	14
5.2 Device versions	14
5.3 Name plate	16
6 Description code	17
7 Technical Data	21
7.1 Pressure limits vs. temperature stainless steel	23
7.2 Dimensions and weights	24
8 Electrical connections	28

1 Safety Instructions

1.1 Intended use

The series *RE 250* of flowmeters with a standard length of 250 mm (9.84 inch) and a completely metal design is suitable for measuring different liquids and gases in closed piping.

The robust design enables the operation in rough conditions. Different types of flanges, liners and float materials meet the requirements of the pharmaceutical and chemical industries.

The devices are particularly suitable for the measurement of:

- Water
- Fluids
- Corrosion protection agents
- Lubricants
- Saturated and superheated steam
- Food and beverages
- Industrial gases

Warning!



The operator of these measuring devices is solely responsible for the suitability, intended use and corrosion resistance of the selected materials. It must be particularly ensured that the materials selected for the wetted parts of the flowmeter are suitable for the process media to be measured.

The manufacturer is not liable for any damage resulting from improper or unintended use of these devices.

No external loads may act upon the meter. The flowmeters are primarily designed for static applications.



Caution!

Hot surfaces resulting from hot process media.

Danger of burns resulting from surface temperatures above 70 °C.

- *Take appropriate protective measures, for example contact protection.*
- *The design of the contact protection must meet the maximum permissible ambient temperature of the meter.*



Caution!

For devices used in hazardous areas, additional safety notes apply; please refer to the Ex documentation!

The flowmeter may only be operated within the pressure and voltage limits specified on the name plate.

Before taking the flowmeter out of operations, check that the unit is free of hazardous media and de-pressurized.

1.2 Certifications

CE marking



The manufacturer certifies for the device RE 250 meets all statutory requirements of the following EU directives by applying the CE marking:

- Pressure equipment directive 2014/68/EU
- Low voltage directive 2014/35/EU *
- EMC-directive 2014/30/EU
- NAMUR recommandation NE21 *
- ATEX directive 2014/34/EU **

(*Devices with electrical installations)

(**Devices for use in hazardous areas)

1.3 Safety instructions from the manufacturer

Disclaimer

The manufacturer will not be liable for any damage resulting from the use of its product, including, but not limited to direct, indirect, incidental, punitive and consequential damages.

Any product purchased from the manufacturer is warranted in accordance with the relevant product documentation and our Terms and Conditions of Sale.

The manufacturer reserves the right to revise the content of its documents, including this disclaimer, without prior notification, and will not be liable in any way for possible consequences of such changes.

Product liability and warranty

MECON GmbH assumes no guarantee for repair work carried out by the customer without prior notification and consultation. Any instruments or parts rejected by a customer must be returned to us, if no other arrangement has been made.

General information

This manual is intended for the correct installation as well as operation and maintenance of the devices. Read the instructions carefully before installing the device and placing it into operation.

Specially designed or customized models and specialized applications are not included in this manual.

2 Start-up

2.1 Standard device

When starting up the device, the following points must be observed:

- Ensure that the actual operation conditions (pressure, temperature) do not exceed the limits which are given on the nameplate of the device
- Avoid float impacts!
Therefore it is recommended to start up with a closed shut-off valve to be opened slowly. The use of solenoid valves is not recommended.
- When measuring liquids, the pipes must be vented slowly to prevent shock pressure due to gas bubbles.
- When measuring gases, the pressure must be increased slowly in order to prevent high shock pressure.
- During start-up of new systems, residual materials may be carried in the medium and could adhere to the float. In such cases it is recommended to clean the instrument after a relatively short period of operation.
- When operating the flowmeter at low flowrates, the device has to start-up with a high flowrate to allow the float to level out. This will ensure measurements within the specified accuracy class.

Special issues for measuring gas flow:

- Valves have to be installed downstream of the device if $p_{abs} > 1.013$ bar and upstream of the device if $p_{abs} = 1.013$ bar (free outflow).
- Install a throttle just downstream of the device to prevent compression oscillations during measurement.
- Ensure that the operating pressure for the flowmeter corresponds to the calibration reference pressure to avoid erroneous measurements.

Float damping

A float damping is recommended

- in general for measuring gases
- where piping vibrations can not be avoided

It is also strongly recommended in the case of:

- applications where air bubbles in the medium cannot be avoided
- possibility of shock pressure in the piping, e.g. due to rapid throttling or process shut-off
- turbulence, pulsations, etc. which could lead to vibrations of the flowmeter
- rapid pressure build-up in the piping

2.2 Device with current output (MEM)

The magneto-electrical measuring transducer (MEM) is factory-set when it is delivered to the customer.

After applying the supply voltage to the device, initially the current output will be about 3.5 mA to 4 mA for a few seconds. After that a current corresponding to the pointer deflection will flow.



Important!

Due to the influence of the float magnet, the MEM transmitter will only output the correct current if the pointer position is caused by the float. Turning the pointer manually will cause incorrect values, but it is suitable for testing the unit.

2.3 Device with limit switches

The limit switches can be set over the entire measuring range by varying the position of the limit pointers.



Important!

*Unless otherwise specified by the customer, the factory set value for the switching point on versions with one limit switch is about **40% of URV** and for devices with two limit switches it is about **20% / 80% of URV**.*

To set the limit switches at the desired position the following steps have to be observed:

- Unloosen the two small fixing screws (2) before moving the pointer (1).
- Move the pointer to the desired position.
- Tighten the screws to fix the pointer.

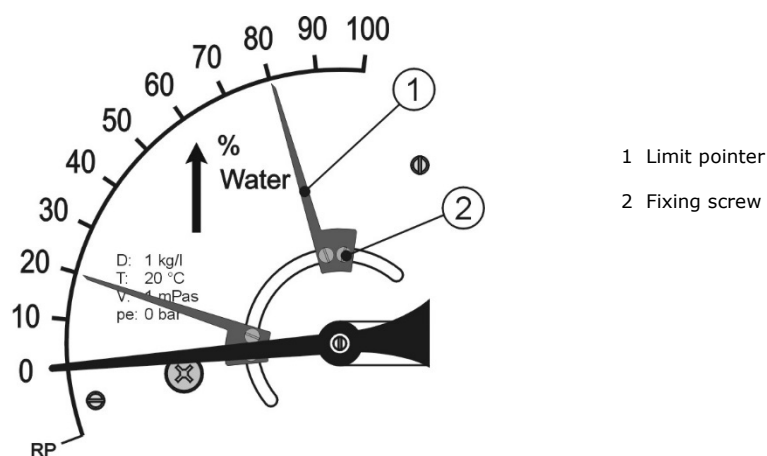

Fig. 2 Adjustment of the switching point (limit switch)

3 Installation and mode of operation

3.1 Notes on installation

**Information !**

All instruments are carefully checked for functional capability before shipment. Upon receipt of the device please carry out a visual inspection of the outer packing for damage or improper handling.

Please contact the delivery carrier if you discover any defects. In such cases a description of the defect, the type and the serial number of the device are needed.

**Information !**

Unpack the equipment with care to prevent damage.

**Information !**

All instruments are carefully checked for order conformity. Please check the delivery for completeness using the packing list. Please examine the flowmeter nameplate to verify that the device was built according to your order. Particularly check devices with electrical components for the correct supply voltage.

3.2 Installation

Below the essential points concerning installation are described and have to be observed:

- Remove the transport securing device from the fitting.
- Prior to the installation verify that the float slides smoothly in the fitting without canting or deadlocking. The pointer must follow the float movement smoothly.
- Verify that all accessories such as spring stop, gas/fluid damping are still correctly fixed in the fitting.
- In the zero position (no flow) the pointer must be at the marked reference point (first line on the scale). When moving the float manually to the end position, the pointer must be above the final value of the scale.
- The flowmeter must be installed vertically – flow direction from bottom to top. For installation recommendations refer to guideline VDI/VDE 3513 Part 3.
- The installation in the piping must be tension-free – therefore the piping must be positioned parallel and aligned with each other.
- Avoid a corrosive atmosphere –provide ventilation where necessary.
- Ensure a sufficient distance of at least 200 mm to magnet-influencing parts such as solenoid valves or ferromagnetic components e.g. steel brackets.
- Observe a lateral distance of at least 300 mm between two devices mounted next to one another. The distance can be reduced by mounting the devices staggered by the length of one device. To eliminate doubt the influence can be tested by moving the instrument up and down

ca. 200 mm at a selected distance while observing whether the position of the pointer on the display changes.

- Specify the installation zone regarding a reliable reading of the displayed values and adequate spacing for servicing.
- An inlet run upstream and an outlet run downstream the device is not necessary in case of a linear media flow profile. In cases of highly asymmetrical flow profiles, however, additional measures (e.g. inlet tracks, flow rectifiers) with a length of at least 250 mm could be appropriate to ensure the measuring accuracy.
- Avoid the installation of unilaterally constricting fittings upstream of the device.
- Ensure that the piping is installed securely to avoid vibration or oscillation of the devices.
- The nominal width of the flowmeter and the connected piping must be identically.
- Use connectors connecting bolts suitable for the particular device version (dimension, pressure rating).
- Ensure that the clearance between the flanges of the piping corresponds to the device dimension in addition to two gaskets.
- Before connecting the device, blow or flush out the pipes leading to the device.
- The surface roughness of the flange sealing areas must be appropriate for the used gaskets.
- The gaskets and bolts of the prescribed dimensions must be appropriate for the operating pressure, the temperature and the media.
- **Do not use carbon steel mounting brackets for the device!**

Additionally for devices with PTFE liner:

- Use gaskets which conform to the inner and outer dimensions of the raised face of the flowmeter.
- Tighten the screws crosswise to ensure the tightness of the process connections. For tightening torques please refer to Tab. "2.2 Tightening torques".
- If the instrument is absolutely calibrated for a pressure exceeding 1.013 bar any valve is usually installed at the rear of the flowmeter, at 1.013 bar absolute (free emanation) in front of the instrument.

Special issues for measuring gas flow:

- Valves have to be installed downstream of the device if $p_{abs} > 1.013$ bar and upstream of the device if $p_{abs} = 1.013$ bar (free outflow).
- Install a throttle just downstream of the device to prevent compression oscillations during measurement.
- Ensure that the operating pressure for the flowmeter corresponds to the calibration reference pressure to avoid erroneous measurements.

Tightening torques

The flange bolts for devices with PTFE liner may be tightened with the following torques (acc. guideline VDI/VDE 3513):

Process connection		max. torque	
EN1092-1	ANSI B16.5	Nm	ft·lbf
15	½"	14	10
25	1"	14	10
40	1 ½"	25	18
50	2"	25	18
80	3"	35	25
100	4"	42	30

Tab 2.2 Tightening torques for devices with PTFE liner

Magnetic filters

To prevent a malfunction of the flowmeter caused by ferromagnetic substances contained in the medium (such as weld beads) a magnetic filter should be mounted in flow direction upstream of the instrument.

This kind of filter is also recommended if such particles cannot be avoided in standard operation.

3.3 Operating principle

Like other devices of this series the variable area flowmeter *RE 250* operates according to the principle of flotation:

The measuring unit consists of a metal tube with a measuring ring in which a float can move up and down. The media is flowing upwards through the tube and raises the conical float. Here the annular gap enlarges until the equilibrium between the buoyancy force F_A , the drag force F_S and the weight of the float F_G is reached. The adjusted height of the float is directly proportional to the flowrate. The movement of the float is transmitted via a magnet inside the float to a corresponding magnet inside the display unit outside of the measuring pipe.

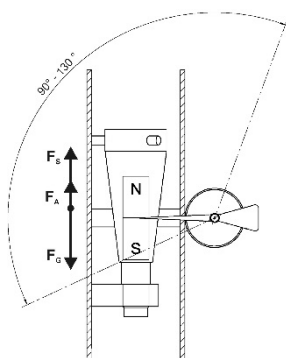

Fig. 1 Operating principle of the RE 250

3.4 Classification

Classification in accordance with the Pressure Equipment Directive 2014/68/EU:

Process connection		Admissible media	Category
EN1092-1	ANSI B16.5		
DN 15	½"	Gases and fluids of fluid group 1	Art. 4.3
DN 20	¾"	Gases and fluids of fluid group 1	Art. 4.3
DN 25	1"	Gases and fluids of fluid group 1	Art. 4.3
DN 32	1 ¼"	Gases and fluids of fluid group 1	III
DN 40	1 ½"	Gases and fluids of fluid group 1	III
DN 50	2"	Gases and fluids of fluid group 1	III
DN 65	2 ½"	Gases and fluids of fluid group 1	III
DN 80	3"	Gases and fluids of fluid group 1	III
DN 100	4"	Gases and fluids of fluid group 1	III
DN 125	5"	Gases and fluids of fluid group 1	III
DN 150	6"	Gases and fluids of fluid group 1	III

4 Service

4.1 Storage

- Store the device in a dry and dust-free place.
- Keep away from direct sun and heat.
- Avoid external loads to the device.
- The storage temperature range for standard devices with electrical components is -40 ... +70 °C / -40 ... +158 °F.

4.2 Maintenance and cleaning

The devices are built for low maintenance operations but periodically the flowmeters should be inspected for signs of corrosion, mechanical wear as well as damage to the fitting and the display unit.

We advise to carry out inspections at least once a year.

For a detailed inspection and cleaning the device must be removed from the piping.



Caution!

*Appropriate safety precautions have to be taken when removing the device.
Always use new gaskets when reinstalling the device in the piping.*

4.3 Replacing float

Devices with measuring ring

For devices with standard measuring ranges starting from 5 - 50 l/h (gases: 0.15 - 1.5 m³/h) the replacement of the float can be provided by the customer:

- Remove the device from the piping.
- Fix the device ideally in a horizontal position, ensuring that the fitting will not be damaged.
- Prevent the float ① from torsion by fixing the upper guide bracket ② using a suitable tool.
- Remove the self-locking nut ③ which fixes the lower guide bracket ④ and take the guide bracket out of the fitting.
- Take the float upwards out of the measuring unit.
- Insert the new float into the fitting from the top. At the same time carefully guide the bottom end of the float through the measuring ring.
- Slip the lower guide bracket through the thread at the bottom end of the float and fix it with the self-locking nut.
- Install the device back into the piping.

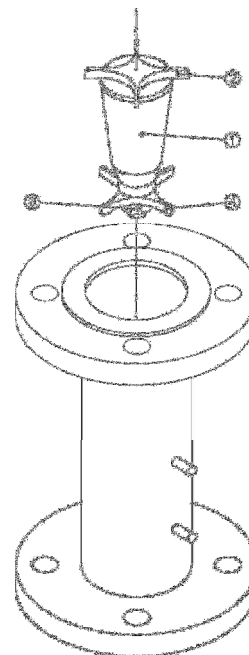

- 1 Float
- 2 Upper guide bracket
- 3 Self-locking nut
- 4 Lower guide bracket

Fig. 4 Replacing floats



Important!
Avoid damaging both float and measuring ring.



Important!
After float replacement a recalibration of the flowmeter is highly recommended, otherwise the measurement accuracy cannot be ensured.

Devices with cone

- Replacing floats for devices with cone (standard measuring ranges up to 5 - 50 l/h (gases: 0.15 - 1.5 m³/h) cannot be done by the customer. The device has to be returned to the manufacturer. For details please refer to chapter "6.4 Returning the device to the manufacturer".

4.4 Replacing float damping

Devices with measuring ring

For devices with standard measuring ranges starting from 5 - 50 l/h (gases: 0.15 – 1.5 m³/h) the float damping can be replaced by the customer:

- Remove the device from the piping.
- Fix the device, ensuring that the fitting will not be damaged.
- The damping cylinder ⑥ is fixed by retaining clamps ⑤. Bend up these two clamps carefully using a suitable tool.
- Move the damping cylinder slightly to the bottom end of the fitting, make a quarter turn and take the cylinder out of the fitting.
- Insert the new damping cylinder into the fitting from the top, slide it over the damping part of the float and arrange it into the retaining clamps.
- Fix the cylinder by bending the retaining clamps together.
- Install the device back into the piping.

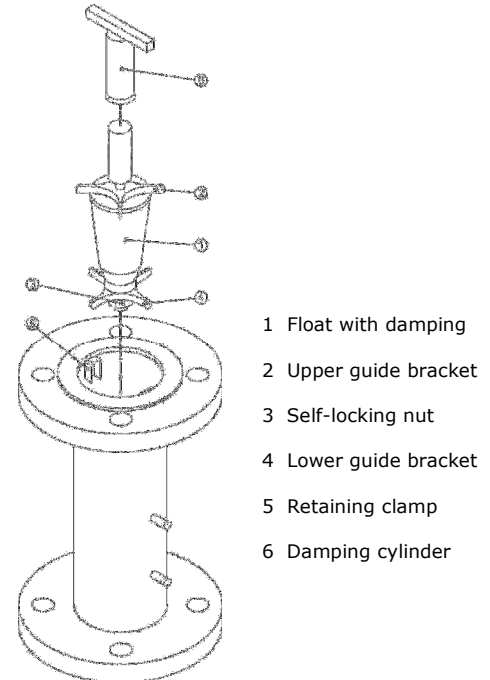

Fig. 3 Replacing float damping

4.5 Returning the device to the manufacturer

This device has been carefully manufactured and tested. Should you nevertheless need to return a device to MECON GmbH please observe the following points:



Caution!

According to the actual waste disposal directives, the owner/customer is responsible for the waste management of hazardous and toxic waste.

*For reasons of environmental protection and safeguarding the health and safety of our personnel **all devices sent to MECON GmbH to be repaired must be free of toxic and hazardous substances. This also applies to cavities of the devices. If necessary the customer is kindly requested to neutralize or rinse the devices before returning them to MECON.***

The customer has to confirm this by filling in an appropriate form which is available for download on the MECON website:

www.mecon.de/en/Declaration/Decontamination.pdf

5 Device Description

5.1 Scope of delivery

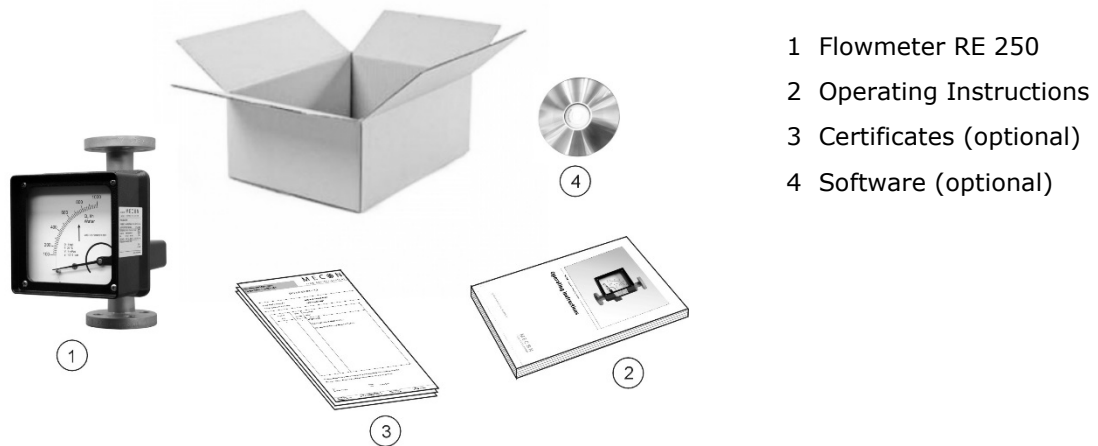

Fig. 5 Scope of delivery



Information!

Please check the delivery for completeness using the packing list.

5.2 Device versions

Display unit made of aluminium

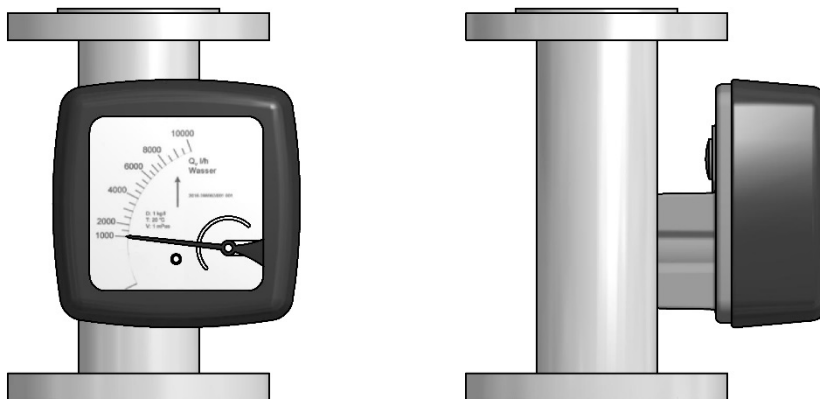

The measurement range is indicated directly on the scale. The equipment can be supplied with auxiliary electrical components and touch-sensitive switches for process monitoring and control.

Display unit made of stainless steel

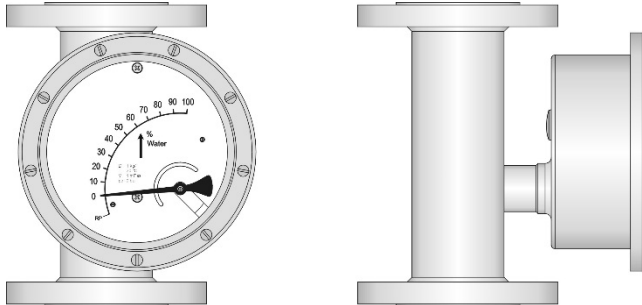
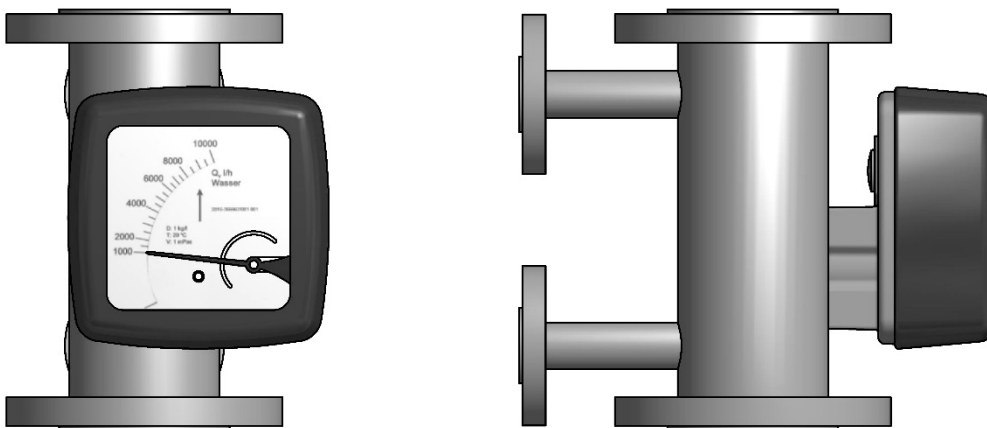

Fig. 7 Standard device with display unit made of stainless steel

For applications with requirements for higher protection category or corrosion resistance the devices are available with a display unit made of stainless steel.

Heating shield



For installations where temperature drops are unacceptable the devices are available with an external heating shield.

5.3 Nameplate



Important!

Please refer to the device nameplate to ensure that the device is built according to your order.

Check particularly for the correct supply voltage.

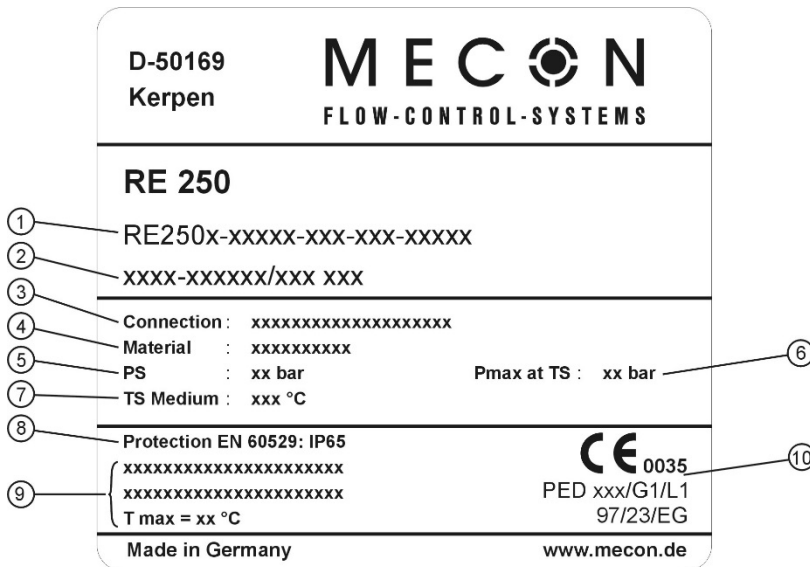

- | | | |
|---|----------------------|--|
| ① | Code number | Device specific code number |
| ② | Year / Serial number | Device specific serial number and the year it was built |
| ③ | Connection | Connection type of the device |
| ④ | Material | Material of the wetted parts |
| ⑤ | PS | Maximum pressure of the medium |
| ⑥ | Pmax at TS | Maximum pressure of the medium at temperature TS |
| ⑦ | TS Medium | Maximum temperature of the medium |
| ⑧ | Protection | Protection class for the housing of display |
| ⑨ | MEM specification | Electrical specifications of the output / transducer (MEM) |
| ⑩ | Category | Category acc. to Pressure Equipment directive (PED) |

Fig. 9 Nameplate of the RE 250

6 Description code

Individual part for versions CF-S (stainless steel) and EF-H (Hastelloy®)

The description code consists of the following elements:

RE 250 - - - -

① Flow tube

A	DN 15
B	DN 25
C	DN 40
D	DN 50
E	DN 80
F	DN 100

② Version

1	CF-S	wetted parts: stainless steel
2	EF-H	wetted parts: Hastelloy®

③ Process connections

Flanges

		EN1092-1	ANSI B16.5	Flow tube EN						Flow tube ANSI							
				A	B	C	D	E	F	A	B	C	D	E	F		
Nominal size	Axx	DN 15	½"	●	○							●	○				
	Bxx	DN 20	¾"	●	●							●	●				
	Cxx	DN 25	1"	●	●	○						●	●	○			
	Dxx	DN 32	1 ¼"	●	●	●						●	●	●			
	Exx	DN 40	1 ½"	●	●	●	○					●	●	●			
	Fxx	DN 50	2"	●	●	●	●					●	●	●	●		
	Gxx	DN 65	2 ½"		●	●	●	○					●	●	●		
	Hxx	DN 80	3"			●	●	●					●	●	●		
	Jxx	DN 100	4"				●	●	●					●	●	●	
	Kxx	DN 125	5"						●	●					●	●	
	Lxx	DN 150	6"							●	●				●	●	

● = available ○ = reduced scale raised face

Pressure rating	xBx	PN 16	(EN 1092-1)	DN65 - DN150
	xDx	PN 40	(EN 1092-1)	DN15 - DN150
	xEx	PN 63	(EN 1092-1)	DN50 - DN150
	xFx	PN 100	(EN 1092-1)	DN15 - DN150
	xGx	PN 160	(EN 1092-1)	DN15 - DN150 (DN 20 and DN 32 not available)
	xHx	150 lbs	(ASME B16.5)	½" - 6"
	xJx	300 lbs	(ASME B16.5)	½" - 6"
Flange form	xxA	B1	(EN 1092-1)	PN16 / PN40
	xxB	B2	(EN 1092-1)	PN63 / DN100
	xxC	Form D	(EN 1092-1)	DN15 - DN150
	xxD	Form C	(EN 1092-1)	DN15 - DN150
	xxG	Form RF	(ASME B16.5)	½" - 6"
xxH	Form FF	(ASME B16.5)	½" - 6"	
xxJ	Form RTJ	(ASME B16.5)	1" - 6"	

③ Process connections (continued)

Threaded connection

Txx	Female thread		Flow tube EN			
xTx	DIN ISO 228		1500lbs	1500lbs	1500lbs	900lbs
xNx	NPT ANSI B 1.20.1		PN100	PN100	PN100	PN63
	DIN ISO 228	ANSI B1.20.1	A	B	C	D
xx7	G ¼	NPT ¼"	●			
xx8	G ⅜	NPT ⅜"	●			
xx1	G ½	NPT ½"	●	●	●	
xx2	G ¾	NPT ¾"	●	●	●	
xx3	G 1	NPT 1"	●	●	●	● max 16 m³/h
xx4	G 1 ¼	NPT 1 ¼"			●	● max 16 m³/h
xx5	G 1 ½	NPT 1 ½"			●	● max 20 m³/h
xx6	G 2	NPT 2"				● max 20 m³/h

④ Heating sheath

● = available

0	Without
1	With flange connection DN15 DIN 2501 PN40 in stainless steel
2	With flange connection DN25 DIN 2501 PN40 in stainless steel
3	With flange connection ½" ANSIB16.5 150RF in stainless steel
4	With flange connection 1" ANSIB16.5 150RF in stainless steel

⑤ Maximum range values / Measuring ranges

	Fluids		Gases		Ratio	Pressure drop [mbar]					
	[l/h]	[USgpm]	[m³/h]	[scfm]		A	B	C	D	E	F
1	5	0,022	0,15	0,088	1:10	40	◇	◇	◇	◇	◇
2	10	0,044	0,30	0,177	1:10	40	◇	◇	◇	◇	◇
3	16	0,07	0,48	0,283	1:10	40	◇	◇	◇	◇	◇
4	25	0,11	0,75	0,441	1:10	40	◇	◇	◇	◇	◇
5	40	0,18	1,3	0,765	1:10	40	◇	◇	◇	◇	◇
A	50	0,22	1,5	0,883	1:10	40	◇	◇	◇	◇	◇
B	70	0,31	2,1	1,24	1:10	40	◇	◇	◇	◇	◇
C	100	0,44	3,0	1,77	1:10	60	◇	◇	◇	◇	◇
D	160	0,70	4,6	2,71	1:10	60	◇	◇	◇	◇	◇
E	250	1,10	7,0	4,12	1:10	60	◇	◇	◇	◇	◇
F	400	1,76	11	6,47	1:10	70	◇	◇	◇	◇	◇
G	600	2,64	17	10,00	1:10	80	◇	◇	◇	◇	◇
H	1000	4,40	30	17,66	1:10	◇	60	◇	◇	◇	◇
J	1600	7,0	46	27,07	1:10	◇	70	◇	◇	◇	◇
K	2500	11,0	70	41,20	1:10	◇	100	50	◇	◇	◇
L	4000	17,6	110	64,74	1:10	◇	240	120	80	◇	◇
M	6000	26,4	170	100,0	1:10	◇	◇	180	90	◇	◇
N	10.000	44,0	290	170,7	1:10	◇	◇	◇	110	◇	◇
P	16.000	70,0	460	270,7	1:10	◇	◇	◇	230	70	◇
Q	20.000	88,0	550	323,7	1:10	◇	◇	◇	230	70	◇
R	25.000	110,0	700	412,0	1:10	◇	◇	◇	500	100	◇
S	40.000	176,0	1.100	647,4	1:10	◇	◇	◇	◇	350	120
T	50.000	220,0	1.350	794,6	1:10	◇	◇	◇	◇	350	120
U	60.000	264,0	1.700	1.000	1:10	◇	◇	◇	◇	◇	360
V	80.000	352,0	2.400	1.413	1:10	◇	◇	◇	◇	◇	600
W	100.000	440,0	3.000	1.766	1:10	◇	◇	◇	◇	◇	600

* devices for media with higher viscosity on request

◇ = not available

⑥ Measured medium

1	Water ($\eta = 1 \text{ mPa}\cdot\text{s}$, $\rho = 1 \text{ kg/l}$)
2	Air ($T = 0 \text{ }^\circ\text{C}$, $p_e = 0 \text{ bar}$, $\eta = 0.0181 \text{ mPa}\cdot\text{s}$, $\rho = 1,293 \text{ kg/m}^3$)
3	Specify in plain text

⑦ Float damping

0	Without float damping
1	With float damping

Description code – common part for all versions

The description code consists of the following elements:

RE 250 - - - -

⑧ Display unit / Process temperature

0	Standard (aluminium)	- up to 200 °C for local display / 150 °C for electric output)
1	Standard (aluminium)	- with displaced display (extension made of stainless steel)
2	Stainless steel IP66	- up to 150 °C
3	Stainless steel IP66	- with displaced display

⑨ Outputs

AA	With local display
CJ	With local display, 1 inductive contact SJ 3,5N
CL	With local display, 2 inductive contacts SJ 3,5N
EA	With local display, electric remote sensor 4-20 mA
EL	With local display, electric remote sensor 4-20 mA, 2 inductive contacts SJ 3,5N
EJ	With local display, electric remote sensor 4-20 mA, 1 inductive contact, 1 pulse output
FA	With HART protocol, 4-20mA
FL	With HART protocol, 4-20mA, 2 inductive contacts
FJ	With HART protocol, 1 inductive contact, 1 pulse output
PA	With PROFIBUS PA interface

⑩ Certification of accuracy

0	Without calibration certificate
1	Certification of accuracy class (4.2.1)
2	With calibration report (5 points)
3	With calibration report incl. Electrical output (min. 5 points)

⑪ Leak / pressure test

0	Without leak/pressure test
1	Pressure test acc. to EN 10204 with inspection certificate 3.1
2	Leak test acc. to EN 10204 with inspection certificate 3.1
3	Pressure test + leak test (acc. to EN 10204 with inspection certificates 3.1)

⑫ Material certificates

A	Without certificate
B	Certificate of Compliance with the Order 2.1 according to DIN EN 10 204
C	Inspection certificate 3.1 with material analysis (DIN EN 10204:2004) for wetted parts

⑬ Cleaning to factory standard

A	Without cleaning
B	Cleaning class VA – with marking: free of oil and grease
C	Cleaning class VA – with marking: free of oil, grease and silicone

⑭ Approvals

0	Without
1	Explosion protection – mechanical approval ATEX EX II 2 GDC
2	Explosion protection – mechanical and electrical (MEM/MEM-PPA) approval ATEX EX ia IIC T6

⑮ Marking

0	Without marking
1	Cardboard plate with a cable tie
2	Stainless steel plate (dimensions 70 x 30mm)
3	Cardboard plate with cable tie + stainless steel plate (dimensions 70 x 30 mm)

7 Technical Data

General data

<i>Range of application</i>	Flow measurement of liquids and gases
<i>Measuring principle</i>	Flotation / Float measuring
<i>Orientation</i>	Vertical – flow direction from bottom to top

Measuring accuracy*

<i>Directive</i>	VDI / VDE 3513, sheet 2 (qG = 50%)
<i>Liquids</i>	G 1.6 (add. 0,2%** of URV for MEM/MEM-PPA)
<i>Gases</i>	G 2.5 (add. 0,2%** of URV for MEM/MEM-PPA)
<i>Reproducibility</i>	0,5% of URV (add. 0,1% of URV for MEM/MEM-PPA)

* A variation of the operating temperature to the considered temperature for the calibration process, will lead to a corresponding inherent error

** For ambient temperatures < -20 °C the measuring error will increase

Materials

		Type CF-S	Type EF-H	Type FF-P
<i>Wetted parts</i>		Stainless steel	Hastelloy®	PTFE
<i>Flange</i>	<= DN25 (1")	Stainless steel	Hastelloy®	Stainless steel
	> DN25 (1")		Hastelloy® stainless	
<i>Fitting <= DN25</i>	<= DN25 (1")	Stainless steel	Hastelloy®	Stainless steel with PTFE liner
	> DN25 (1")		Hastelloy® stainless	
<i>Float + Guide bracket</i>		Stainless steel	Hastelloy®	PTFE

<i>Display unit</i>	Aluminium (optional stainless steel 1.4301) with safety glass pane
---------------------	--

Operating conditions – all devices

Temperature

	Type CF-S	Type EF-H	Type FF-P
<i>Max. Medium temp. TS</i>	-20 °C ...+200 °C (opt. -80 °C ...+300 °C)		-20 °C ...+125 °C

Pressure

		Type CF-S	Type EF-H	Type FF-P
<i>Max. Medium pressure PS</i>	DN15 – DN150:	PN160 (optional up to 400 bar)		PN16
	½" – 6":	580 psi (optional up to 5800 psi)		232 psi
<i>Min. operating pressure</i>		> 2 x pressure loss (see measuring ranges)		
<i>Climate classification</i>		Weatherproof and/or non heated locations Class C in accordance with DIN IEC 654 Section 1		
Protection class (DIN EN 60529)				
<i>Display unit</i>		made of aluminium: IP65 made of stainless steel: IP66		

Temperatures

Device version	Ambient temperature*		Storage temperature	
	[°C]	[°F]	[°C]	[°F]
without electrical components	-40 ...+80	-40 ...+176	-40 ...+80	-40 ...+176
with limit switch(es)	-40 ...+65	-40 ...+149	-40 ...+65	-40 ...+149
with 4 ... 20mA output	-40 ...+70	-40 ...+158	-40 ...+70	-40 ...+158

*** IMPORTANT !**



For applications in hazardous areas it is mandatory that the temperature class of the type examination certificate (protection type) will be observed.

For devices used in hazardous areas, additional safety notes apply; please refer to the Ex documentation!

RE 250 with limit switch(es)

Cable gland	M20 x1.5
Isolation (2 contacts)	Galvanic isolated
Terminal connection	2.5 mm ²
Limit switch	SJ3.5-N-BU
Switching function	NAMUR, NC
Nominal voltage U _o	8.2 V DC (R _i approx. 1 kΩ)
Supply voltage	5 ... 25 V DC

RE 250 with current output 4 ... 20 mA

Cable gland	M20 x1.5
Terminal connection	2.5 mm ²
Auxiliary supply voltage U _B	14 V ... 30 V DC
Measuring signal	4 ... 20 mA = 0 ... 100% flow value in 2-wire technology
Power supply influence	< 0.1 %
Max. external load R _B	680 Ω (30 V) R _B = (U _B - 14V) / 22 mA
Temperature influence	< 10 μA / K

RE 250 with current output 4 ... 20 mA and HART®-Protokoll + digital output

Switching function	NAMUR (EN 60947-5-6:2000)
Max. voltage	30 V DC
Max. power consumption	100 mW
Current (state: open)	type 0,4 mA
Current (state: closed)	type 0,4 mA
Pulse output	
Max. rate	10 Hz
Pulse width	approx. 50 ms

7.1 Pressure limits vs. temperature stainless steel

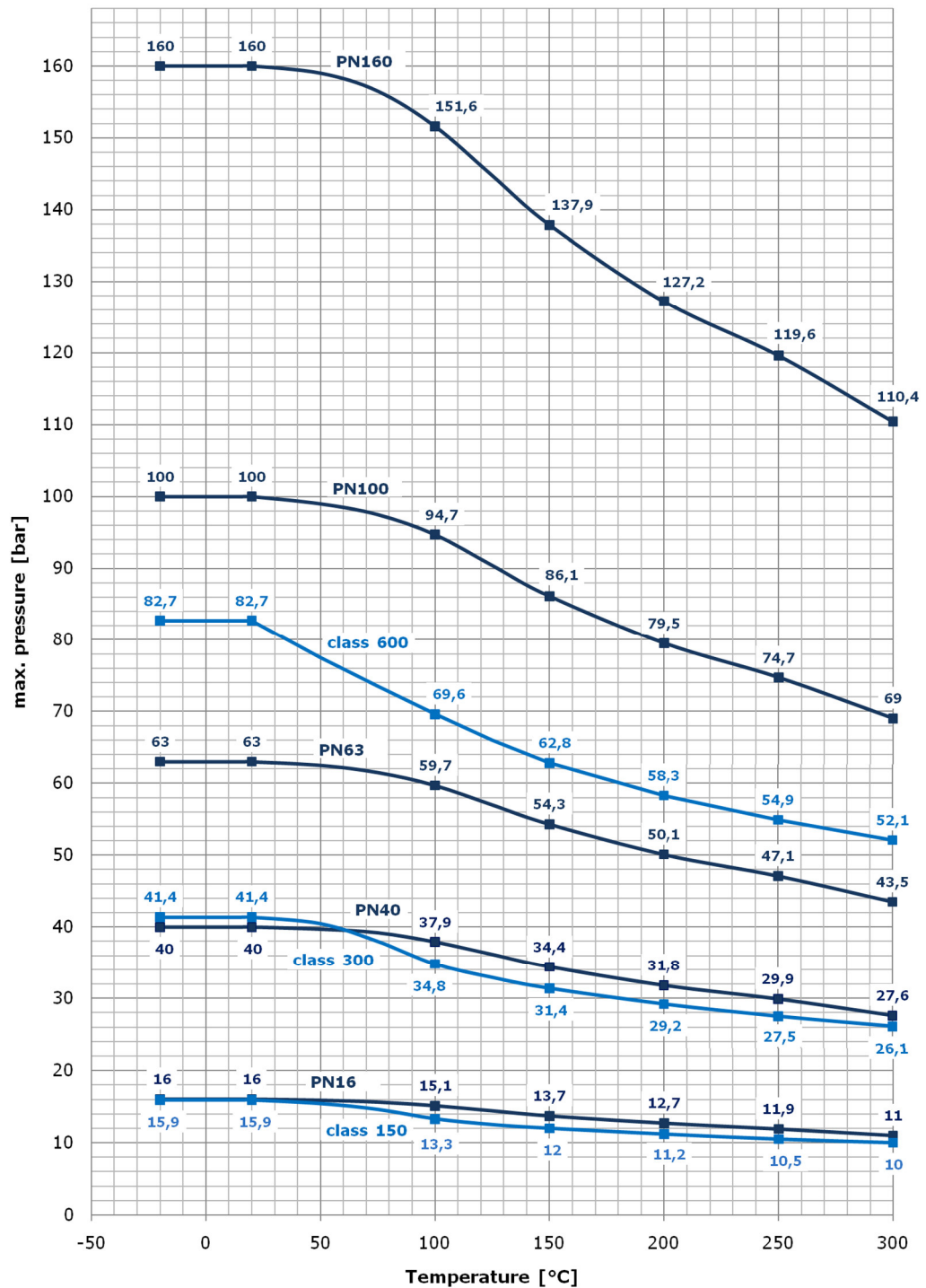
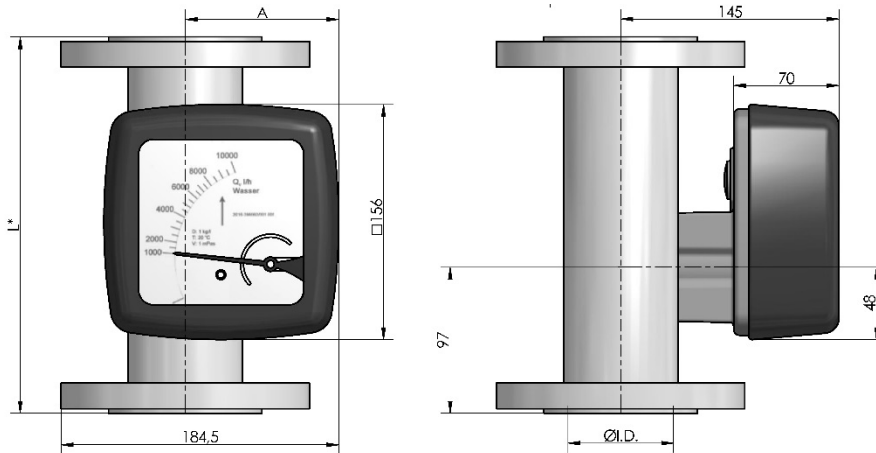

Fig. 10 Maximum Pressure PS vs. temperature TS

7.2 Dimensions and weights

Standard version (Housing of display made of aluminium)



DN	ANSI	Ø I.D.	A	Weight
15	½"	26 (1,02)	74 (2,91)	3,0 (6,6)
20	¾"	26 (1,02)	74 (2,91)	3,0 (6,6)
25	1"	32 (1,26)	77 (3,03)	4,2 (9,3)
32	1 ¼"	32 (1,26)	77 (3,03)	5,2 (11,5)
40	1 ½"	46 (1,81)	88 (3,46)	6,0 (13,2)
50	2"	70 (2,76)	97 (3,82)	7,5 (16,5)
65	2 ½"	70 (2,76)	97 (3,82)	8,5 (18,7)
80	3"	102 (4,02)	113 (4,45)	13,0 (28,7)
100	4"	125 (4,92)	126 (4,96)	18,0 (39,7)
125	5"	125 (4,92)	126 (4,96)	22,0 (48,4)
150	6"	125 (4,92)	126 (4,96)	25,0 (55,0)

All Dimensions in mm (inch)

weights in kg (lbs)

* For dimension L please refer to page 27.

Heating shield version

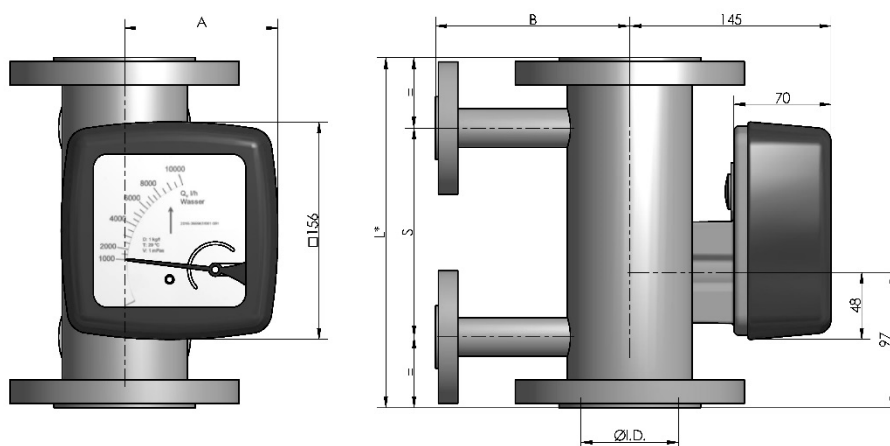

DN	ANSI	Ø I.D.	A	B	S	Weight
15	½"	26 (1,02)	74 (2,91)	110 (4,33)	150 (5,91)	4,7 (10,4)
20	¾"	26 (1,02)	74 (2,91)	110 (4,33)	150 (5,91)	4,7 (10,4)
25	1"	32 (1,26)	77 (3,03)	110 (4,33)	150 (5,91)	5,9 (13,0)
32	1 ¼"	32 (1,26)	77 (3,03)	110 (4,33)	150 (5,91)	6,9 (15,2)
40	1 ½"	46 (1,81)	88 (3,46)	130 (5,12)	150 (5,91)	7,8 (17,2)
50	2"	70 (2,76)	97 (3,82)	140 (5,51)	150 (5,91)	9,6 (21,1)
65	2 ½"	70 (2,76)	97 (3,82)	140 (5,51)	150 (5,91)	11,0 (24,2)
80	3"	102 (4,02)	113 (4,45)	160 (6,30)	150 (5,91)	16,0 (35,2)
100	4"	125 (4,92)	126 (4,96)	175 (6,89)	120 (4,72)	22,0 (48,4)
125	5"	125 (4,92)	126 (4,96)	175 (6,89)	120 (4,72)	26,0 (57,2)
150	6"	125 (4,92)	126 (4,96)	175 (6,89)	120 (4,72)	29,0 (63,8)

All Dimensions in mm (inch)

weights in kg (lbs)

* For dimension L please refer to page 27.

Stainless steel version

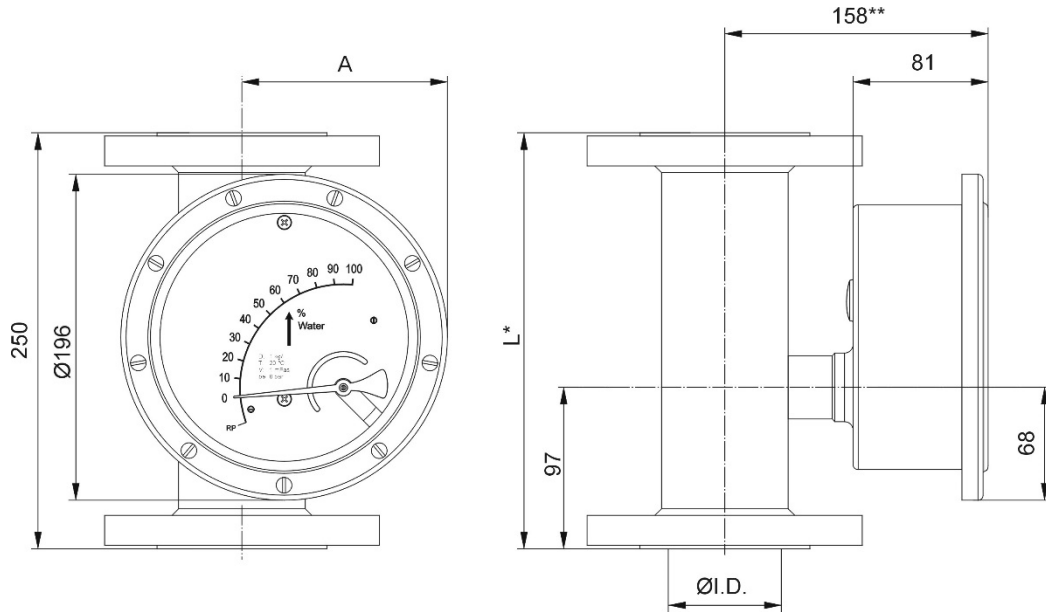

DN	ANSI	Ø I.D.	A	Weight
15	½"	26 (1,02)	103 (4,06)	3,1(6,8)
20	¾"	26 (1,02)	103 (4,06)	3,1(6,8)
25	1"	32 (1,26)	105 (4,13)	4,3(9,5)
32	1 ¼"	32 (1,26)	105 (4,13)	5,3(11,7)
40	1 ½"	46 (1,81)	115 (4,53)	6,1(13,4)
50	2"	70 (2,76)	129 (5,08)	7,6(16,7)
65	2 ½"	70 (2,76)	129 (5,08)	8,6(18,9)
80	3"	102 (4,02)	145 (5,71)	13,1(28,9)
100	4"	125 (4,92)	158 (6,22)	18,1(39,9)
125	5"	125(4,92)	158 (6,22)	22,1(48,6)
150	6"	125(4,92)	158 (6,22)	25,1(55,2)

All Dimensions in mm (inch)

weights in kg (lbs)

* For dimension L please refer to page 27.

** Dimension will be 258 mm for version with displaced display unit

Mounting dimension L

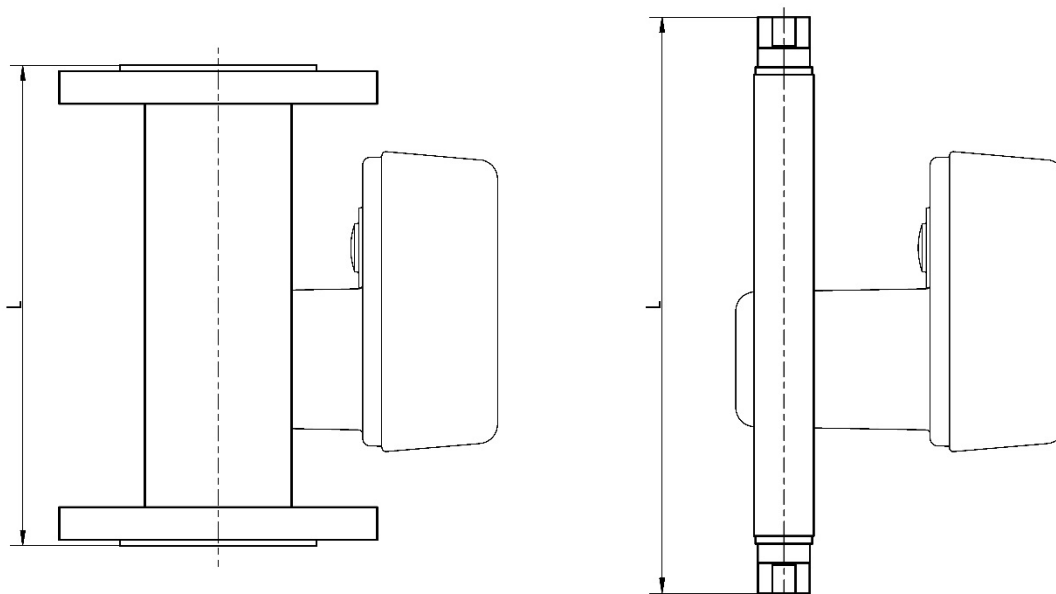

Nom. Dia.	EN				Nom. Dia.	ANSI		
	PN 16	PN 40	PN 63	PN 100		150 lbs	300 lbs	600 lbs
DN 15	◇	250	◇	250	1/2"	250	250	250
DN 20	◇	250	◇	250	3/4"	250	250	250
DN 25	◇	250	◇	250	1"	250	250	250
DN 32	◇	250	◇	250	1 1/4"	250	250	250
DN 40	◇	250	◇	250	1 1/2"	250	250	250
DN 50	◇	250	250	300	2"	250	250	300
DN 65	250	250	◇	◇	2 1/2"	250	300	300
DN 80	250	250	◇	◇	3"	250	300	300
DN 100	250	250	◇	◇	4"	250	300	300
DN 125	250	300	◇	◇	5"	250	300	◇
DN 150	250	300	◇	◇	6"	250	300	◇

All Dimensions in mm

◇ = not available

Devices with threaded connection:

Mounting dimension L: 300 mm

Special feature ANSI B16.5 1/2" for measuring tube B (measuring range end value 1000 /1600 /2500 /4000 l/h):

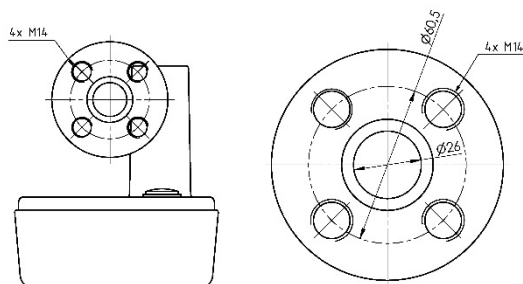

8 Electrical Connections

Safety instructions



Warning!

All work on the electrical connections may only be carried out by a specialist. Ensure that the power is disconnected.

Observe all occupational safety regulations. It is essential to observe the voltage data on the nameplate.

Electrical connections

The display lid can be removed by loosening the four mounting screws at the front. Insert the connection cable through the cable gland at the baseplate. The RE 250 is equipped with screw terminals.

Limit switches

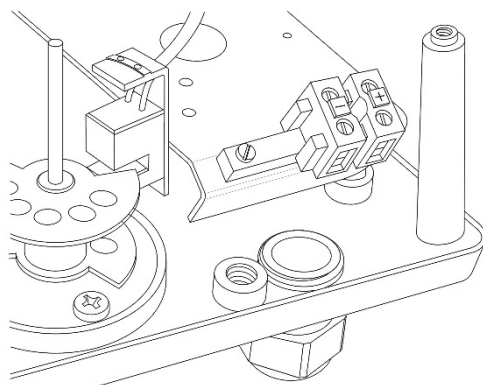

Fig. 11 Terminals (one limit switch)

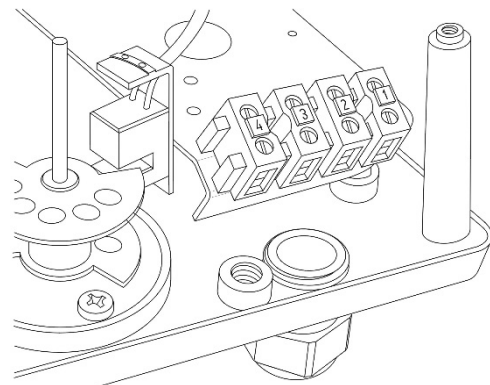

Fig. 12 Terminals (two limit switches)

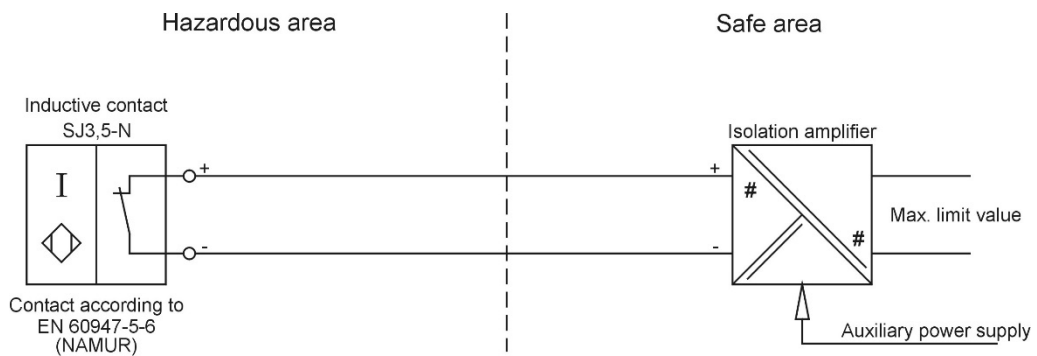

Fig. 13 Connection diagram for RE 250 with one limit switch

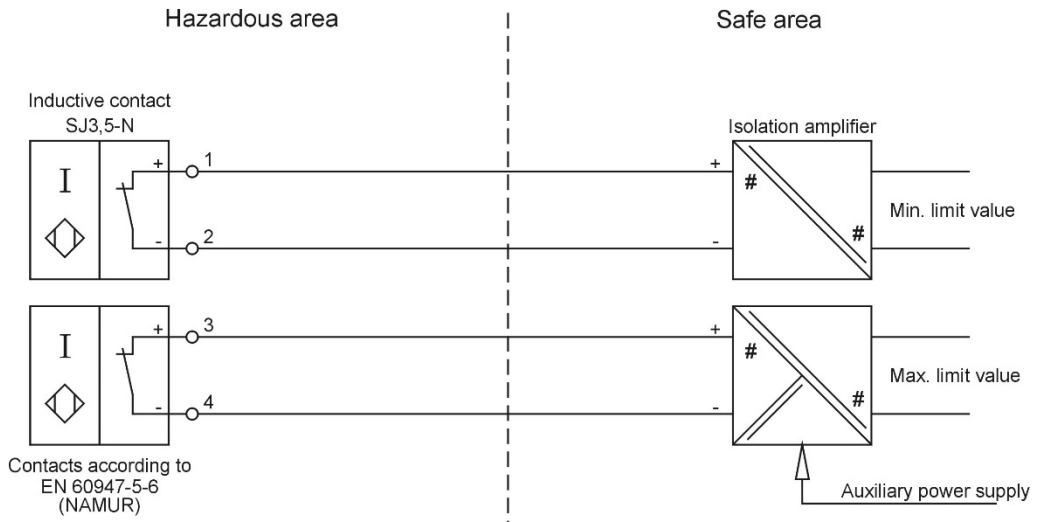

Fig. 14 Connection diagram for RE 250 with two limit switches

Current output (MEM)

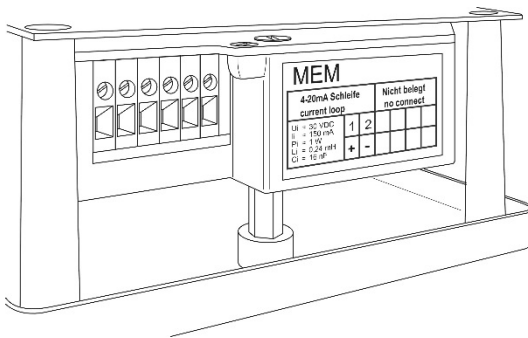

Fig. 15 Terminals (current output) outputs)

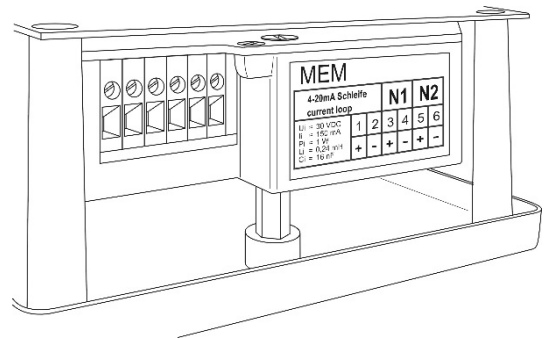

Fig. 16 Terminals (with add. digital outputs)

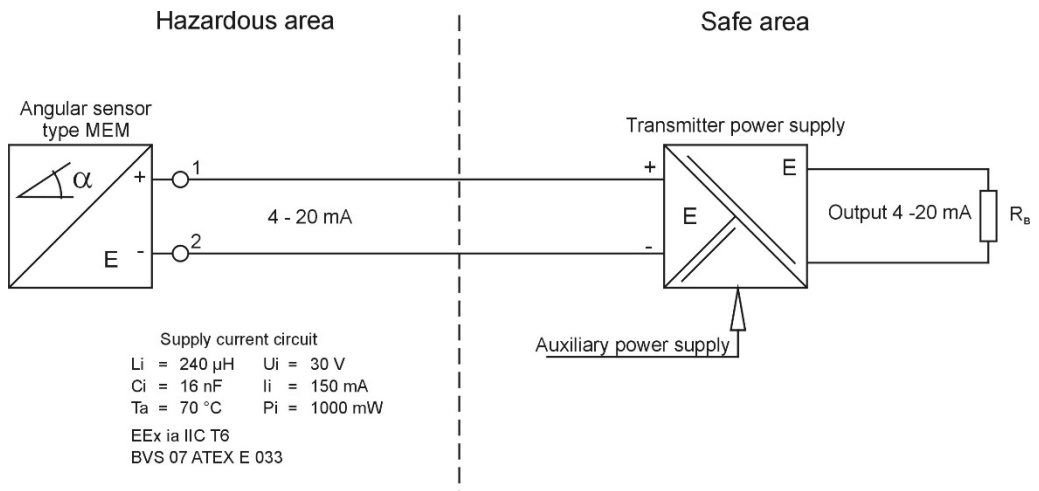

Fig. 17 Connection diagram for transducer MEM with current output

Current output with digital outputs (MEM)

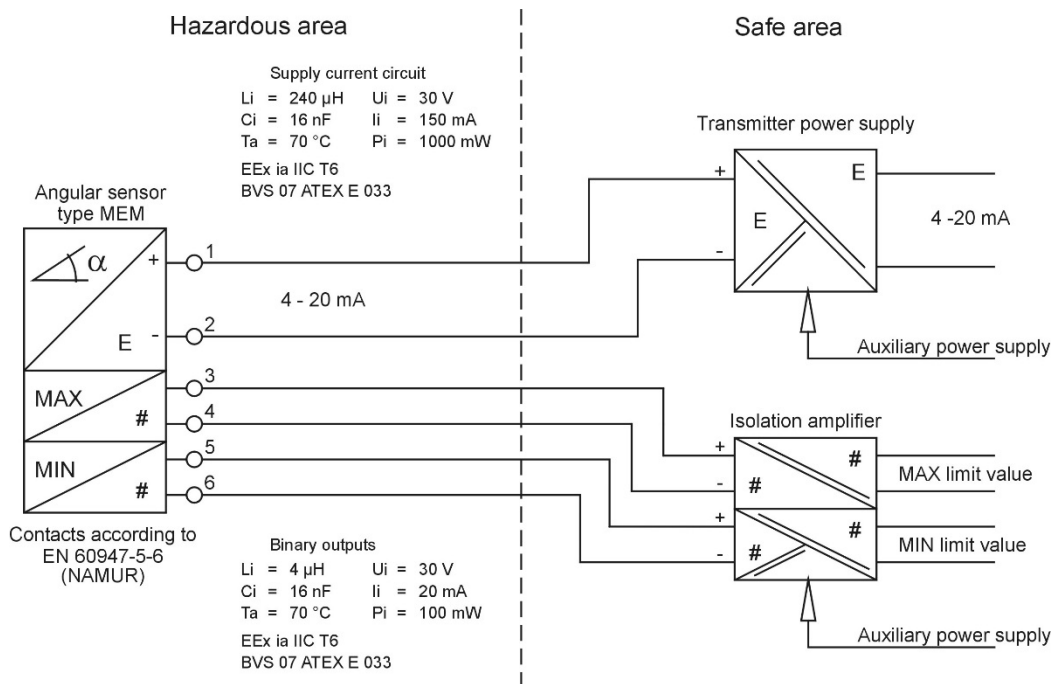

Fig. 18 Connection diagram for transducer MEM with 2 limit switches

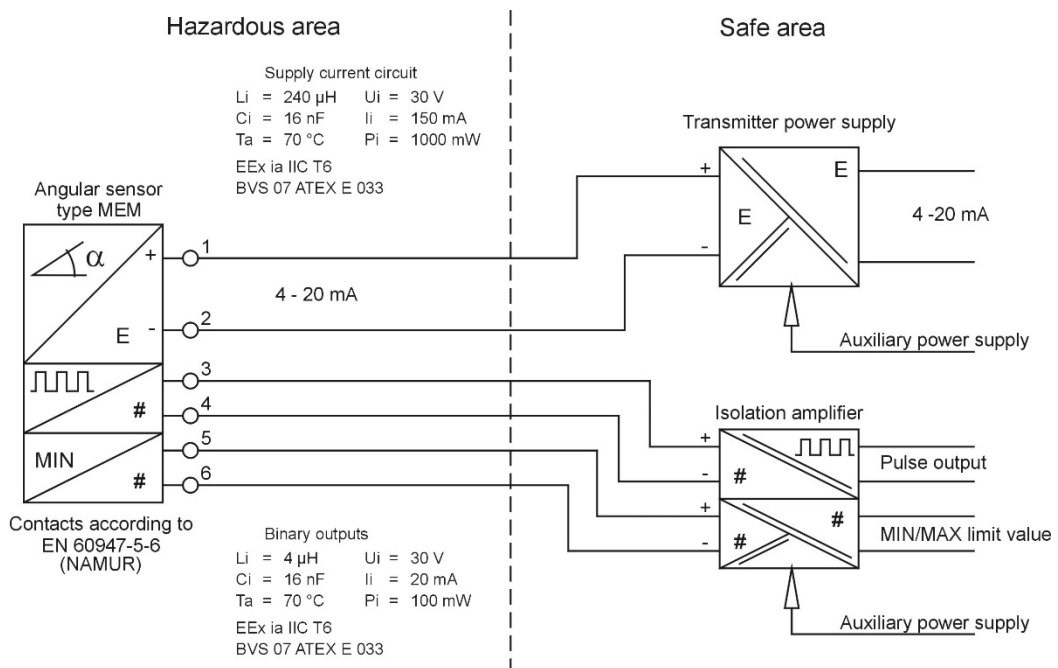

Fig. 19 Connection diagram for transducer MEM with limit switch and pulse output

Current output with HART®-Protocol (MEM)



Abb.20 Connecting terminal of the RE 250 with current output and HART®-Protocol (MEM)



Abb.21 Wiring diagram for the transmitter with current output and HART®-Protocol (MEM)

Protection class

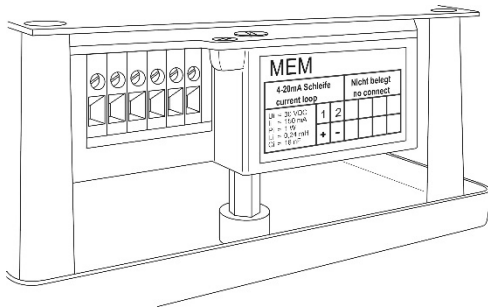
The protection class of the display unit made of aluminium is class IP65. The version made of stainless steel will meet all requirements of protection class IP66.

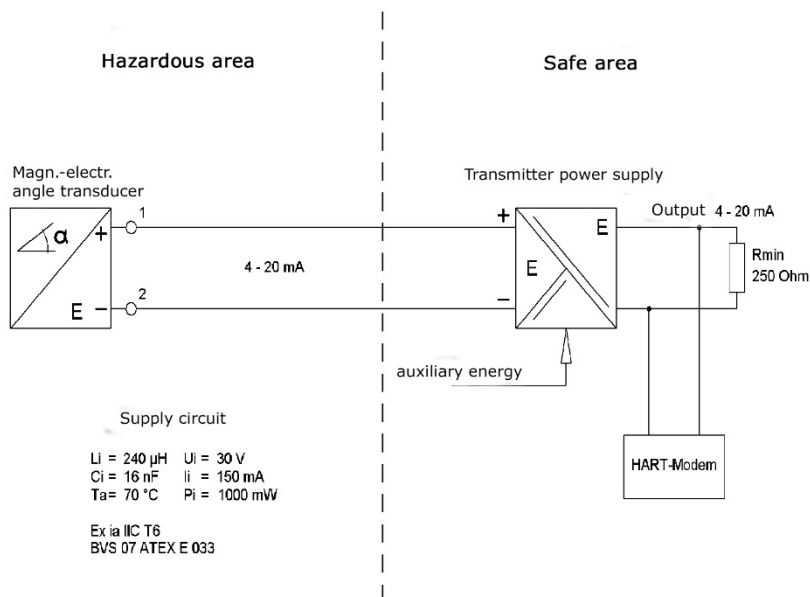

Caution!

After installation or maintenance work on the device, the operator has to check and ensure the specified protection class again.

Therefore pay attention to the following issues:

- Mounting screws of the display unit must be tightened.
- All gaskets (display unit and cable glands) have to be undamaged. Broken gaskets have to be replaced.
- The electrical cable glands must be free of any damage and tightened. Broken cable glands have to be replaced.
- Install the cables with a loop in front of the cable glands so that moisture does not enter the display unit (refer to Fig. 4.5)

MECON GmbH

Röntgenstr. 105
50169 Kerpen / Germany

Tel.: +49 (0)2237 600 06 - 0
Fax.: +49 (0)2237 600 06 - 40
Email: info@mecon.de

www.mecon.de

