



Fig. 1 F O N4 orifice flowmeter

### Application

The F O N4 orifice flowmeter is used to measure the flow of transparent liquids in closed piping. Any mounting location, position and flow direction can be selected for the flowmeter. The flowmeter can also be used for flow monitoring if equipped with limit contacts.

### Design and mode of operation

The F O N4 orifice flowmeter primarily consists of an orifice plate as the sensor and a float as the display element. A differential pressure is produced across the orifice plate which is fitted in the main stream between two flanges in the piping. In a bypass, this differential pressure produces a volume flow in a variable area meter. The height of the float indicates the flow rate. The flow is read at the position of the float's widest diameter.

### Installation and start-up

- The measuring regulations for the flow DIN EN ISO 5167 not only include the version of orifice units but also require an installation conforming to standards so that the indicated uncertainty in measurement can be kept. The standard installation must already be considered during the projecting of the pipeline. The orifice unit must be installed in a straight pipeline which is long enough. Bends, valves and the like must be installed in such a distance of the orifice unit that the trouble has faded there. Orifice units with large diameters are highly sensitive to troubles.
- Observe the recommendations with respect to inlet and outlet pipe sections for the orifice plate according to DIN EN ISO 5167 at page 5
- Align orifice with the sharp edge (+ marking) to the entry side
- Insert differential pressure sensor with gaskets concentrically between the flanges of the pipeline and tighten uniformly.
- Loosen the union nut (G2), align the indicating part vertically downwards and then tighten union nut.
- For floats with magnets and contact switches, lead the float along the whole contact to the polarization during the start-up.

### Special features

- Suitable for any mounting positions without reduction in accuracy
- Complies with requirements for treatment and disinfection of swimming/ bathing pools (DIN 19 643)
- Simple installation
- Direct visualization of flow rate in bypass

### Maintenance

Contamination, especially around the bypass orifice, may lead to faults in the measurement. The bypass orifice plate can be dismounted and cleaned without interrupting the main flow if the ball valves are closed first.

### Contact assembly

The bistable contact assembly K18 consists of a contact spring set sealed in a glass tube filled with protective gas. The contact springs are polarized by a fixed magnet such that they exhibit a bistable response.

Retrofitting of contact switches is only possible if the floats used are equipped with magnets.

Two contacts can be selected:

- K18 A: contact closes when the limit is fallen below
- K18 B: contact closes when the limit is exceeded.

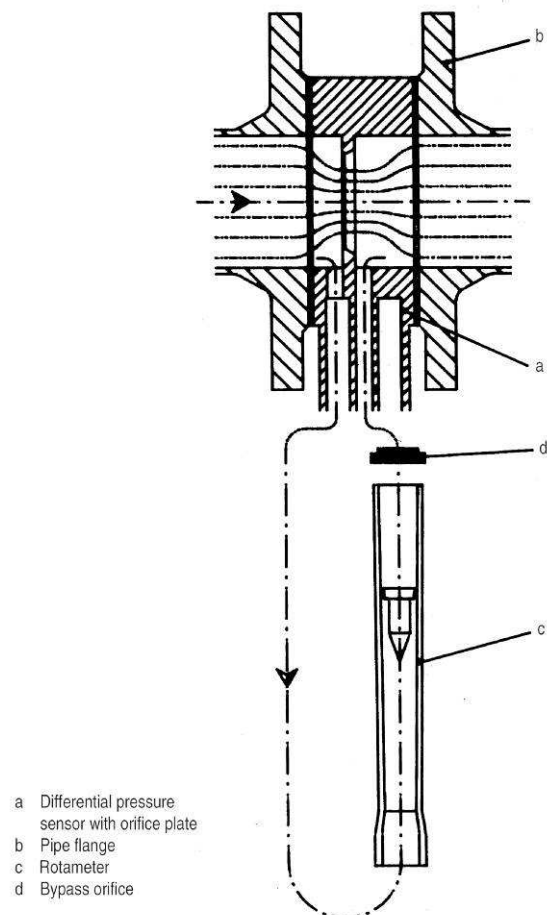

Fig. 2 Measuring principle

# Orifice flowmeter F O N4

## Technical specifications

<b>Application</b>	See page 1
<b>Mode of operation</b>	See page 1
Measuring principle	Orifice plate as differential pressure sensor with variable area meter in bypass
<b>Input</b>	
Flow	Any
<b>Rated operating conditions</b>	
<b>Ambient conditions</b>	
Temperature and pressure limits	
• With water and non-corrosive liquids	≤ 40°C (104°F) 10 bar (145 psi) 50 °C (122°F) 6,25 bar (90,64 psi) 60 °C (140 °F) 2,5 bar (36,25 psi)
• With corrosive liquids	≤ 20°C (68°F) 10 bar (145 psi) 40 °C (104°F) 4 bar (58 psi) 60°C (140 °F) 1 bar (14,5 psi)
Medium conditions	
• Accuracy	± 2% of full scale value
• Measuring range	See Table right
- for liquids	0,6 to 1.600 m <sup>3</sup> /h (2,64 to 7.045 USgpm) A special scale must be provided for liquids with a density other than 1 kg/l (62,43 lb/cu.ft)
• Dimensions for measured variable	m <sup>3</sup> /h
Viscosity limits for all measuring ranges	1,0 to 1,3 mPas·s (cp)
<b>Design</b>	
Metering tube connections	Ring between DIN-Flanges of nominal pressure rating PN 10/145 psi DN 25/1" to DN 400/16" (DIN 2501)
Inlet and outlet pipe sections	According to DIN EN ISO 5167, see also delta p: Inlet and outlet pipe sections page 1
Wetted parts materials	
• Ring	PVC
• Orifice plate	PVC, PP, stainless steel, mat.No. 1.4571/316Ti, as option
• Flow tube	Trogamid T can be used with water up to 50°C (122°F), otherwise up to 60°C (140°F) or polysulfone for use up to 60°C (140°F)
• Ball cocks	PVC / PP
• Connecting tube	PVC / PP
• Float	Stainless steel, mat.No. 1.4305/303, optional: stainless steel, mat.No. 1.4571/316Ti, PVC
• Limits	Polysulfone
• Gasket	Buna N/ Neoprene
• Bypass orifice plate	Stainless steel, mat.No. 1.4571/316Ti, optional PVC
<b>Certificates and approvals</b>	
Classification according to PED 97/23/EC	For liquids of fluid group 2; complies with requirements of article 3, paragraph 3 (sound engineering practice SEP)

## Contacts

K18 A	Closes when the limit is fallen below
K 18 B	Opens when the limit is fallen below
Housing/Plug	PP/PA 6
Contact material	Rhodium
Degree of protection	IP 65
Ambient temperature	-20 to +60 °C (-4 to 140°F)
Max. switching frequency	5/min
Max. rating K18 A/B	AC 250 V/0,5 A/10 VA DC 250 V/0,5 A/5 W
	Rating data apply to resistive loads; a suppressor circuit is required for inductive loads.

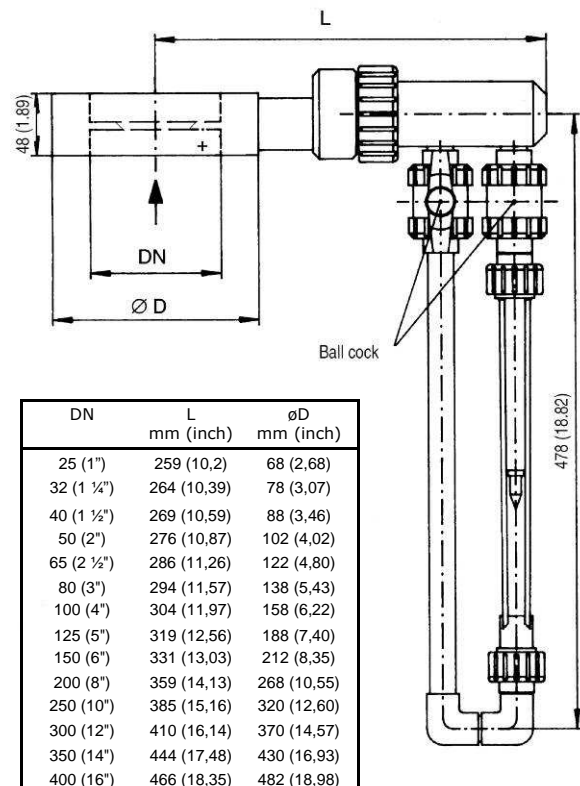

Fig. 3 F O N4, dimensions in mm (inch)

## Note of application

It must be ensured that the materials selected for the parts of the meter coming into contact with the media are suitable for the used process media. The device may only be used within the pressure and voltage limits specified on the identification plate. Before replacing the measuring tubes, check that the device is free of hazardous media and pressures. The device is primarily designed for steady loads. The flowmeter meets the requirements of Article 3 Paragraph 3 of the PED 97/23/EC. It must only be used for Group 2 liquids.

### Measuring ranges for liquids

Standard measuring ranges for liquid: ( $\rho = 1 \text{ kg/l}$  (62,43 lb/cu.ft), viscosity 1 mPa·s (1 cp))

Nominal diameter		Measuring range (Input pressure $\geq 0,5 \text{ bar}$ (7,25psi))		Pressure consumption		Diameter ratio	Weight	
DN	(inch)	m <sup>3</sup> /h	(Usgpm)	$\Delta p$ mbar	(psi)	B	kg	(lb)
25	(1)	0,6 bis 3,0	(2,64 bis 13,2)	335	(4,86)	0,54	1,4	(3,09)
		0,9 bis 4,5	(3,96 bis 19,8)	250	(3,63)	0,64		
		1,2 bis 6,0	(5,28 bis 26,4)	205	(2,97)	0,72		
32	(1 ¼)	0,8 bis 4,0	(3,52 bis 17,6)	335	(4,86)	0,48	1,4	(3,09)
		1,5 bis 7,5	(6,6 bis 33,0)	250	(3,63)	0,64		
		2,0 bis 10,0	(8,8 bis 44,0)	205	(2,97)	0,72		
40	(1 ½)	1,2 to 6,0	(5,28 to 26,4)	335	(4,86)	0,48	1,5	(3,31)
		2,0 to 10,0	(8,8 to 44,0)	275	(3,99)	0,60		
		3,2 to 16,0	(14,1 to 70,0)	200	(2,90)	0,73		
50	(2)	2,0 to 10,0	(8,8 to 44,0)	330	(4,79)	0,49	1,6	(3,53)
		3,0 to 15,0	(13,2 to 66,0)	280	(4,06)	0,59		
		5,0 to 25,0	(22,0 to 110,0)	200	(2,90)	0,73		
65	(2 ½)	3,2 to 16,0	(14,1 to 70,0)	330	(4,79)	0,48	1,8	(3,97)
		6,0 to 30,0	(26,4 to 132,0)	250	(3,63)	0,64		
		8,0 to 40,0	(35,0 to 176,0)	210	(3,05)	0,72		
		9,0 to 45,0	(39,6 to 198,1)	200	(2,90)	0,75		
80	(3)	5,0 to 25,0	(22,0 to 110,0)	330	(4,79)	0,49	1,9	(4,19)
		10,0 to 50,0	(44,0 to 220,0)	240	(3,48)	0,66		
		13,0 to 65,0	(57,0 to 286,0)	200	(2,90)	0,74		
		15,0 to 75,0	(66,0 to 330,2)	190	(2,76)	0,78		
100	(4)	10,0 to 50,0	(44,0 to 220,0)	300	(4,35)	0,55	2,0	(4,41)
		16,0 to 80,0	(70,0 to 352,0)	235	(3,41)	0,67		
		20,0 to 100,0	(88,0 to 440,0)	200	(2,90)	0,73		
		24,0 to 120,0	(105,7 to 528,3)	190	(2,76)	0,78		
125	(5)	13,0 to 65,0	(57,0 to 286,0)	325	(4,71)	0,50	2,3	(5,07)
		24,0 to 120,0	(106,0 to 528,0)	245	(3,55)	0,66		
		32,0 to 160,0	(141,0 to 704,0)	200	(2,90)	0,74		
		39,0 to 195,0	(171,7 to 858,4)	190	(2,76)	0,79		
150	(6)	20,0 to 100,0	(88,0 to 440,0)	315	(4,57)	0,52	2,5	(5,51)
		32,0 to 160,0	(141,0 to 704,0)	245	(3,55)	0,64		
		50,0 to 250,0	(220,0 to 1100,0)	180	(2,61)	0,76		
		54,0 to 270,0	(237,7 to 1188,6)	175	(2,54)	0,78		
200	(8)	34,0 to 170,0	(150,0 to 749,0)	320	(4,64)	0,51	3,1	(6,83)
		60,0 to 300,0	(264,0 to 1321,0)	250	(3,63)	0,65		
		80,0 to 400,0	(352,0 to 1761,0)	200	(2,90)	0,73		
		99,0 to 495,0	(435,8 to 2179,0)	185	(2,68)	0,79		
250	(10)	50,0 to 250,0	(220,0 to 1100,0)	250	(3,63)	0,50	3,5	(7,72)
		80,0 to 400,0	(352,0 to 1761,0)	270	(3,92)	0,61		
		130,0 to 650,0	(572,0 to 2862,0)	200	(2,83)	0,74		
		150,0 to 750,0	(660,3 to 3301,6)	190	(2,76)	0,78		
300	(12)	80,0 to 400,0	(352,0 to 1761,0)	315	(4,57)	0,52	4,1	(9,04)
		120,0 to 600,0	(528,0 to 2642,0)	265	(3,84)	0,62		
		200,0 to 1000,0	(881,0 to 4403,0)	180	(2,61)	0,76		
350	(14)	100,0 to 500,0	(440,0 to 2202,0)	325	(4,71)	0,50	5,1	(11,24)
		200,0 to 1000,0	(881,0 to 4403,0)	235	(3,41)	0,67		
		270,0 to 1300,0	(1189,0 to 5724,0)	190	(2,76)	0,75		
400	(16)	140,0 to 700,0	(616,0 to 3082,0)	320	(4,64)	0,51	5,8	(12,79)
		240,0 to 1200,0	(1057,0 to 5284,0)	250	(3,63)	0,65		
		320,0 to 1600,0	(1409,0 to 7045,0)	200	(2,90)	0,73		

# Orifice flowmeter F O N4

## Ordering data for standard measuring range

F O N4  
Orifice flowmeter

7ME5832-0 00 - 0 A W 0

- Flow tube Trogamid
- Float: mat. No. 1.4305
- Contacts: without
- bypass: PVC
- Orifice: PVC
- Calibration certificate: without

Nom. diam.	Measuring range		
	in	m <sup>3</sup> /h (USgpm)	
DN 25 (1")	0,6 to 3,0	(2,64 to 13,2)	PA
	0,9 to 4,5	(3,96 to 19,8)	PB
	1,2 to 6,0	(5,28 to 26,4)	PC
DN 32 (1 1/4")	0,8 to 4,0	(3,52 to 17,6)	QA
	1,5 to 7,5	(6,6 to 33,0)	QB
	2,0 to 10,0	(14,1 to 70,0)	QC
DN 40 (1 1/2")	1,2 to 6,0	(5,28 to 26,4)	AA
	2,0 to 10,0	(8,8 to 44,0)	AB
	3,2 to 16,0	(14,1 to 70,0)	AC
DN 50 (2")	2,0 to 10,0	(8,8 to 44,0)	BA
	3,0 to 15,0	(13,2 to 66,0)	BB
	5,0 to 25,0	(22,0 to 110,0)	BC
DN 65 (2 1/2")	3,2 to 16,0	(14,1 to 70,0)	CA
	6,0 to 30,0	(26,4 to 132,0)	CB
	9,0 to 45,0	(39,6 to 198,0)	CD
DN 80 (3")	5,0 to 25,0	(22,0 to 110,0)	DA
	10,0 to 50,0	(44,0 to 220,0)	DB
	13,0 to 65,0	(57,0 to 286,0)	DC
	15,0 to 75,0	(66,0 to 330,2)	DD
DN 100 (4")	10,0 to 50,0	(44,0 to 220,0)	EA
	16,0 to 80,0	(70,0 to 352,0)	EB
	20,0 to 100,0	(88,0 to 440,0)	EC
	24,0 to 120,0	(105,7 to 528,3)	ED
DN 125 (5")	13,0 to 65,0	(57,0 to 286,0)	FA
	24,0 to 120,0	(106,0 to 528,0)	FB
	32,0 to 160,0	(141,0 to 704,0)	FC
	39,0 to 195,0	(171,7 to 858,4)	FD
DN 150 (6")	20,0 to 100,0	(88,0 to 440,0)	GA
	32,0 to 160,0	(141,0 to 704,0)	GB
	50,0 to 250,0	(220,0 to 1100,0)	GC
	54,0 to 270,0	(237,7 to 1188,6)	GD
DN 200 (8")	34,0 to 170,0	(150,0 to 749,0)	HA
	60,0 to 300,0	(264,0 to 1321,0)	HB
	80,0 to 400,0	(352,0 to 1761,0)	HC
	99,0 to 495,0	(435,8 to 2179,0)	HD
DN 250 (10")	50,0 to 250,0	(220,0 to 1100,0)	JA
	80,0 to 400,0	(352,0 to 1761,0)	JB
	130,0 to 650,0	(572,0 to 2862,0)	JC
	150,0 to 750,0	(660,3 to 3301,6)	JD
DN 300 (12")	80,0 to 400,0	(352,0 to 1321,0)	KA
	120,0 to 600,0	(528,0 to 2642,0)	KB
	200,0 to 1000,0	(881,0 to 4403,0)	KC
DN 350 (14")	100,0 to 500,0	(440,0 to 2202,0)	LA
	200,0 to 1000,0	(881,0 to 4403,0)	LB
	270,0 to 1300,0	(1189,0 to 5724,0)	LC
DN 400 (16")	140,0 to 700,0	(616,0 to 3082,0)	MA
	240,0 to 1200,0	(1057,0 to 5284,0)	MB
	320,0 to 1600,0	(1409,0 to 7045,0)	MC

## Ordering data for special measuring range/ special version

F O N4  
Orifice flowmeter

7ME5832-0 00 - 0 A W 0

<b>Flow tube</b>	
Trogamid	0
Polysulfone	1
<b>Nominal diameter</b>	
DN 25 (1")	P
DN 32 (1 1/4")	Q
DN 40 (1 1/2")	A
DN 50 (2")	B
DN 65 (2 1/2")	C
DN 80 (3")	D
DN 100 (4")	E
DN 125 (5")	F
DN 150 (6")	G
DN 200 (8")	H
DN 250 (10")	J
DN 300 (12")	K
DN 350 (14")	L
DN 400 (16")	M
<b>Conenction</b>	
DIN 2501	0
ANSI B16.5 150 RF	1
<b>Float</b>	
<b>Material</b>	
- Mat.No. 1.4305/303	0
- Mat.No. 1.4571/316Ti	1
- Mat.No. 1.4571/316Ti with Magnet	2
- PVC weighted	3
- PVC weighted, with magnet	4
<b>Flange connection standard</b>	
- DIN 2501	0
- ASME B16.5 150 RF	1
<b>Contacts (only with magnetic float)</b>	
Without	0
- Contact K 18/A (closes when limit is fallen below)	1
- Contact K 18/B (closes when limit is exceeded)	2
- 2 contacts K 18/A	3
- 2 contacts K 18/B	4
- 1 each Kontakt K 18/A und K 18/B	5
<b>Connection tube / Orifice</b>	
- PVC / PP	AW
- PP / PP	BW
- PVC / Stainless steel mat.No.1.4571	B
- PP / Stainless steel mat.No.1.4571	Q
Nominal diameter DN 25 (1")	P
Nominal diameter DN 32 (1 1/4")	Q
Nominal diameter DN 40 (1 1/2")	A
Nominal diameter DN 50 (2")	B
Nominal diameter DN 65 (2 1/2")	C
Nominal diameter DN 80 (3")	D
Nominal diameter DN 100 (4")	E
Nominal diameter DN 125 (5")	F
Nominal diameter DN 150 (6")	G
Nominal diameter DN 200 (8")	H
Nominal diameter DN 250 (10")	J
Nominal diameter DN 300 (12")	K
Nominal diameter DN 350 (14")	L
Nominal diameter DN 400 (16")	M
<b>Calibration certificate</b>	
- Without	0
- With calibration certificate	1
<b>Further designs</b>	
Please add "-Z" to Order No. And specify Order codes	
<b>Y01</b> measured medium: specify in plain text: medium: always required measuring range with dimension,density with dimension, viscosity with dimension, operating temperature, operating pressure	
<b>Y04</b> Silicone-free version	
<b>Y05</b> Medium: Water; Viscosity: 1 mPa.s (1cp) Density: 1kg/l (62,43lb/cu.ft)	
<b>Y99</b> Specify special version in plain text	