

Fig. 1 Level indicator Menkar K/KM stainless steel

### Application

MECON level indicators from the MENKAR product range are suitable for the continuous measuring and monitoring of the level of a fluid in user defined open or closed vessels. The level in the vessel to be monitored is transmitted via a float analogue in the ratio 1:1 to the indicating scale/magnet flapper type indicator. The measuring is independent of the operating pressure. The units are distinguished by a sturdy construction, trouble free operation and excellent readability, even from a considerable distance.

According to the ambient spatial conditions, the unit can be installed in a horizontal position with two horizontal couplings or with U-shaped standing or suspended connection lines.

The indicating scale can be designed to measure in percentage (0-100% in relation to the distance between the couplings, or in relation to the overall height or the total volume), in volumetric units (m<sup>3</sup> and l) or units of height (m, dm or cm). The mark division is aligned to the height.

Accessories can be supplied comprising different magnet activated contact units for control processes (acoustic or optical signals, motor control and valve control or similar devices). User defined sequence and the number of contacts are only restricted by a specified minimum clearance.

When fluids with a tendency to crystallisation are to be monitored, a steam/hot water jacket heating (terminal connection DN 15 DIN 2501, PN 10), an electric heater or a heat or a cold insulation can be supplied as a special construction.

### Mode of operation

The MENKAR level indicators operate according to the system of communicating tubes or according to the float principle, as described below:

The medium leaves the vessel entering the standpipe through the lower connection line. The measuring float located in the standpipe then floats in the fluid whereby its degree of elevation (in the zone "h") corresponds to the actual level in the vessel.

This degree of elevation or each movement of the float (in the case of alteration in the fluid level) is transmitted via a magnet installed in the measuring float. In the MENKAR "K" on the indicating float element, or in the MENKAR "KM" on the magnetic flappers (turning from white to red). The red side indicates the actual level.

The touch sensitive switches are activated by the measuring float.

The magnetic transmission system operates without contact.

### Special features

- Universal opportunities of application with almost all kinds of fluids
- Simple, sturdy construction with magnetic transmission of measured values
- Strong, magnetic coupling system without mechanical transmission elements
- Excellent readability, even from considerable distances
- can also be supplied for high pressures and temperatures
- User defined number and arrangement of contacts: only limited by the dimensions of the contact housing
- No hydraulic connection between indicating part and medium
- Simple assembly and installation
- Low maintenance
- Selection of materials according to user's needs
- Wide measuring/indicating zone. over 5000 mm in divided design
- can also be supplied with magnet flapper display (Types KM 70—KM 71)

### Type selection

#### MENKAR K 70—K 77

- K 70: with on site display
- K 71: with on site display and touch sensitive switch(es)
- K 72: with on site display and integral transducer 4 -20 mA
- K 76: with touch sensitive switch(es); without on site display
- K 76: with integral transducer 4 -20 mA 4-20mA; without on site display

#### MENKAR KM 70—KM 72

In these types the indicating system consists of a magnet flapper type indicator. The length of the flapper type indicator complies with the indicating zone ("h").

- KM 70: with magnet flapper display
- KM 71: with magnet flapper display and touch sensitive switch(es)
- KM 72: with magnet flapper display and integral transducer 4 - 20 mA

## Level indicator Menkar K/KM stainless steel

### Operating note

The operator of these level indicators is responsible for the suitability, proper use and corrosion resistance of the used materials with regard to the measuring material. It must be ensured that the materials selected for the parts of the level indicator coming into contact with the medium are suitable for the used process media. The level indicator may only be used within the pressure, temperature and voltage limits specified in the operating instructions. Before replacing the standpipe/float, check that the unit is free from hazardous media and pressures. The units are designed for predominantly recumbent load.

The unit meets the requirements of the PED 97/23/EC, article 3, paragraph 3. The most hazardous permissible media are fluids of fluid group 2.

### Assembly/Installation

#### Installation "C":

For side installation in open and closed vessels.

#### Installation "I":

For U-pipe connection, only with closed vessels. Elbow pipes are not included in the scope of delivery.

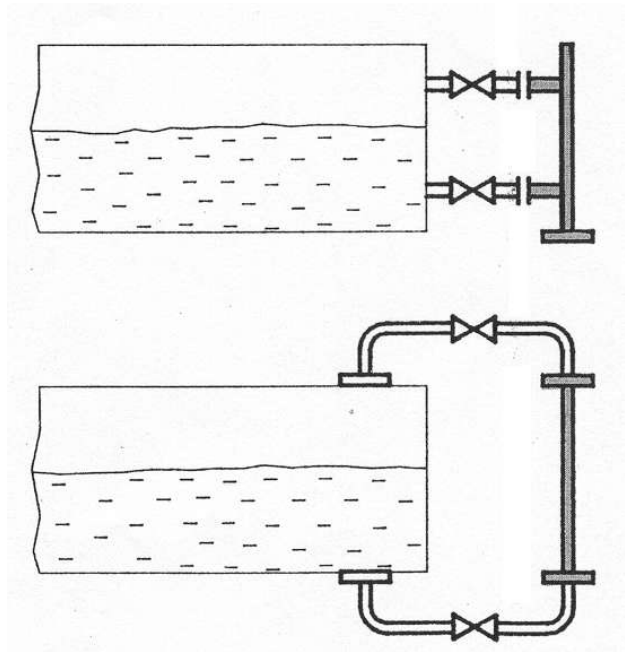

Fig.2 Installation level indicator MENKAR

### Technical data

Measuring/indicating tolerance:	±5 mm
Magnet flapper type indicator:	±10 mm
<b>Measuring range</b>	min.: 300 mm
	max.: - 5000 mm undivided > 5000 mm divided

#### Scale

- Standard %-division
- Option c, m, m<sup>3</sup>-division

**Density of medium** from 0.4 kg/dm<sup>3</sup>

#### Pressure limit\*

- Standard 10 respectively 16 bar
- Option 64 respectively. 320 bar

**Temperature of medium\*** -0...+350°C

**Direction of installation** vertical

#### Connection flange

Standard in accordance with DIN 2501 (installation C)

- for installation "C" DN25/PN40
- for installation "I" DN50/PN40

#### front flanges/blank flange

- for installation B DN25/PN 40
- for installation D Special flange

#### Wetted parts

- Measuring tube (1) Stainless steel
- Connection tubes (2) Stainless steel
- tank connection flanges (3) Stainless steel
- Measuring tube flanges (5) Stainless steel
- Bottom seal flanges (6) Stainless steel
- Indicator tube (7) Plexiglas
- Indicator float (9) Aluminium
- Indicator Scale (10) Aluminium with Astralon insert
- Measuring float see table on page 5

### Project development

The MENKAR units are manufactured, according to type, in installation lengths of up to 5000 mm; longer installation lengths are supplied in a sectioned design to facilitate the transport. The fitting is carried out via flange connections. The following points should be observed corresponding to the respective operating data and the ambient conditions:

- Installation
- Type and design of unit
- Installation length/measuring range
- Type of scale (% , units of volume or height). A volumetric measuring table must be supplied by users requiring volumetric unit scales. The scales may also be subsequently compiled and retrofitted. If rectangular, cubic or cylindrical vessels with flat or convex/concave bottoms in horizontal or vertical arrangement are to be used, the scale can be calculated in volumetric units by the manufacturer (on reimbursement of the net costs involved). The geometric dimensions of the vessel must be supplied to achieve this purpose.
- Gate valve: The equipment of the connection lines with a gate valve is recommended for cleaning purposes and to facilitate the installation and dismantling of the level indicator without the necessity of interruption of operation.

Supplementary data:

- Type of medium (including density and viscosity)
- Operating pressure and operating temperature
- Nominal width and design of the connection flange
- Nominal width and design of the front and blank flanges, in the case of deviation from the standard
- Gasket material

### Design and single parts

#### Design "C"

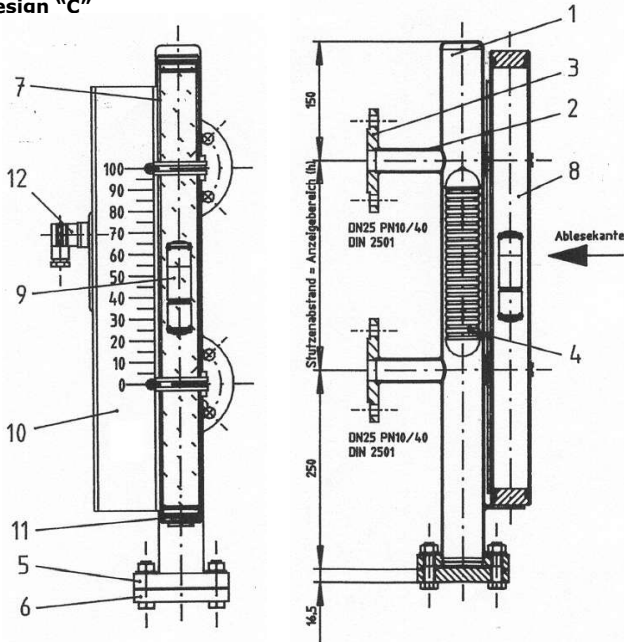

#### Design „I“

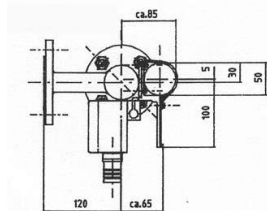
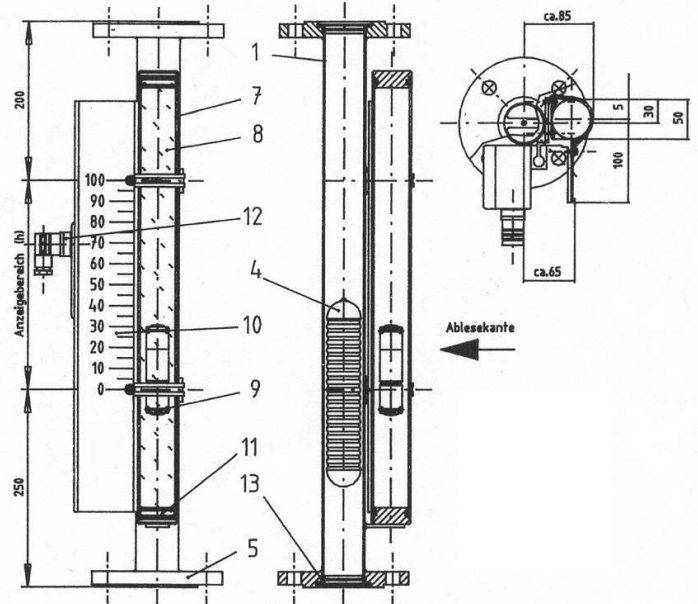

- 1 Standpipe
- 2 Connection couplings\*
- 3 Connection flange\*
- 4 Measuring float
- 5 Front flanges
- 6 Blank flange\*
- 7 Indicating tube
- 8 Indicating fluid (not included in standard scope of delivery)
- 9 Variable area indicator
- 10 Indicating element
- 11 Sealing plug
- 12 Contact
- 13 Retaining ring (only supplied with design "I")
- 14 Air bleed valve\* (Option)
- 15 Bleed valve\* (Option)

\*only supplied with design "C"

### Dimensions drain connection

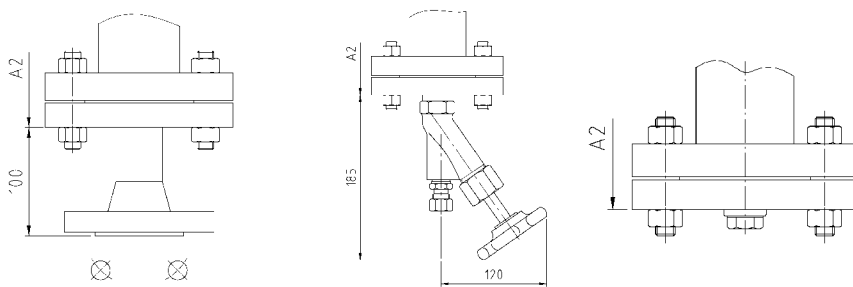

### Dimensions ventilation

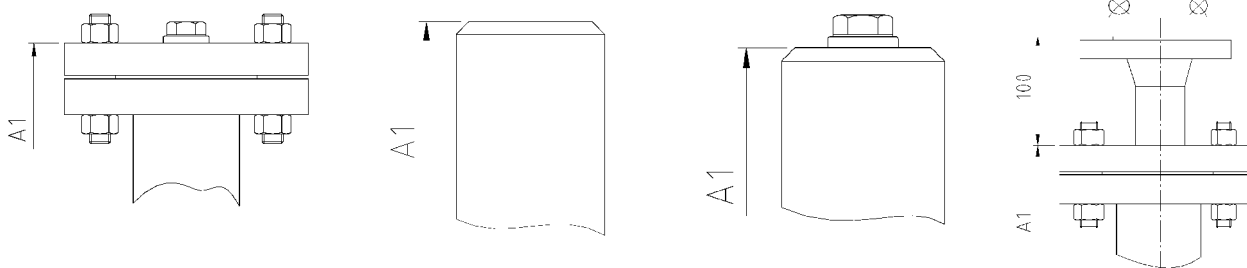

**Level indicator  
Menkar K/KM stainless steel**

**Dimensions: Menkar K 70/KM 70**

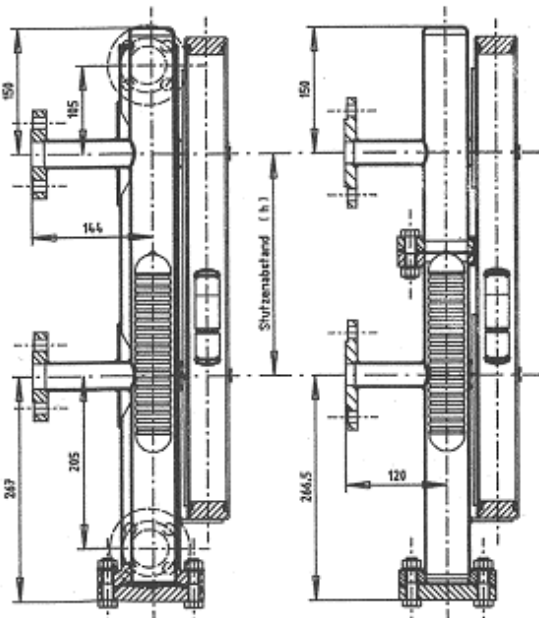
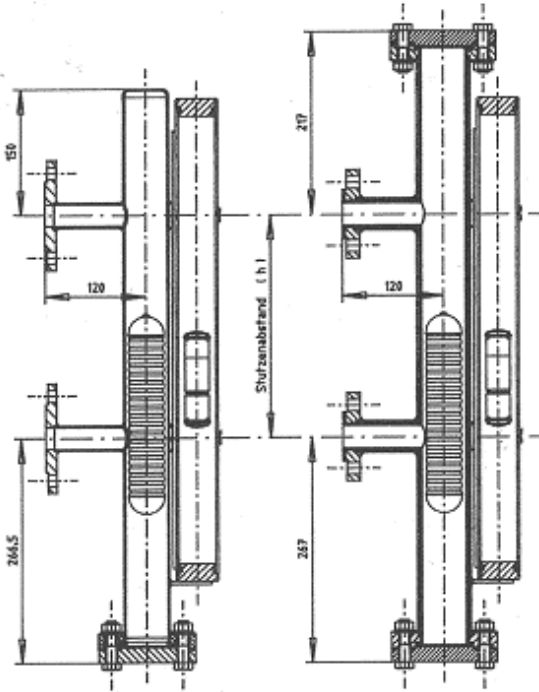

With heating or cooling jacket

With demountable construction

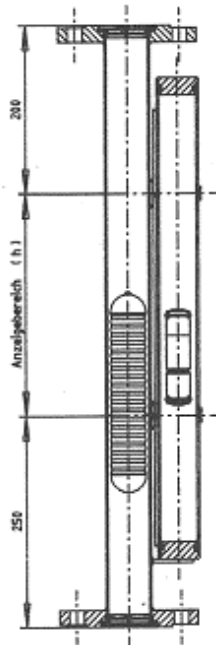

Mounting Form I

**MENKAR KM 70**

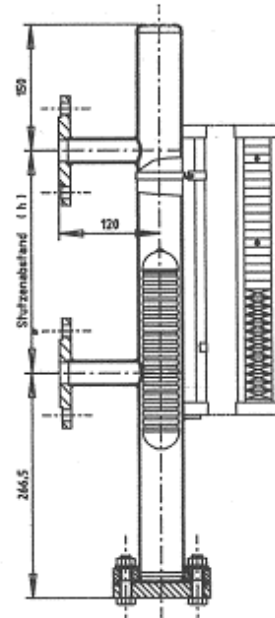

With magnet flapper display

### Selection chart for measuring floats

Nr.	Density [kg/dm <sup>3</sup> ]	Material	Pressure max. [bar]	Temperature max. [°C]	Remarks
1A	0.40 - 0.500	Titanium	10	350	
1B	0.51 - 0.600				
1C	0.61 - 0.700				
1D	0.71 - 0.795				
1E	0.51 - 0.600	Titanium		350	Pressure relieved**
1F	0.61 - 0.700				
1G	0.71 - 0.795				
2	0.60 - 0.675	Titanium	25	350	
3	0.68 - 0.755				
4	0.76 - 0.835				
5	0.85 - 0.950				
6	0.96 - 1.150	1.4571	25 bar at 150°C		
7	1.16 - 1.295		16 bar at 350°C		
8	1.30 - 1.500*				
6A	1.00 - 1.150	1.4571		350	Pressure relieved****
7A	1.16 - 1.295				
8A	1.20 - 1.500*				
9	0.70 - 0.800	Titanium	75	350	
10	0.81 - 0.900				
11	0.91 - 1.000*				
15	0.60 - 0.750	Glass	35	350	without PTFE cladding
16	0.76 - 1.200				with PTFE cladding
17	0.76 - 0.840	Glass	35	220	without PTFE cladding
18	0.85 - 1.200				with PTFE cladding
19	0.85 - 0.950	PVC	6 bar at 60°C		
20	0.96 - 1.150		10 bar at 40°C		
21	1.16 - 1.295				
22	1.30 - 1.200				
23	0.85 - 0.950	PVDF	6 bar at 120°C		
24	0.96 - 1.150		10 bar at 80°C		
25	1.16 - 1.295				
26	1.30 - 1.500				

\* When required for higher density operation, the floats can be weighted accordingly.

\*\* For the prevention of an accumulation of condensate in the measuring float, application is only recommended with buffer gas pressure over the medium!

### Supplementary systems

#### KA 23 and KA 23i:

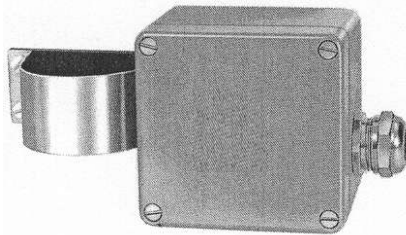

#### KA 33 and KA 33i:

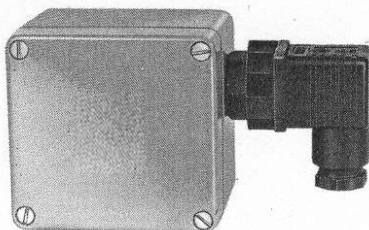

### 1. Magnetic contact systems

Contacts can be selected with reed contacts and inductive slot initiators.

The reed gas contacts can be used directly as a passive switch in existing electric circuits; the inductive contacts require an isolated switch amplifier.

#### 1.1 Reed contacts

These contacts are integrated in the KA 23, KA 33 models. They are distinguished only by their housing respectively by their cable connection. See tables for technical data.

#### 1.2 Inductive contacts

Slot initiators with control lugs are integrated in the KA 23i and KA 33i models. They are employed separately as switches in the intrinsically safe electric circuit. A floating relay output with a changeover contact is available for the connection to the user electric circuit. See tables for technical data.

Technical Data	KA 23	KA 33
	KA 33i	
Housing material	Aluminium	
Protection class	IP 65	
Mounting	Clip on standpipe	Clamps on indicating part
Cable connection	PG11	Hirschmann connector
Type of contact	Protective gas changeover contact made of Ag-Pd, potential free	
	KA 23i, KA 33i: inductive	
Contact rating (max.)	AC: 250V eff./1A/50VA; DC: 250V/1A/100W	

## Level indicator Menkar K/KM stainless steel

### 2. integral transducer

The transducer uses the variable resistance principle. A row of magnetically operated reed switches from an accumulative resistance when actuated by the magnetically coupled measuring float. The row of switches are housed in a non-magnetic stainless steel tube on the outside of the Menkar measuring tube. The magnetic scanning is 15mm. On request, other magnetic scanning is possible.

The transmitter energises the transducer and provides an isolated 4 - 20 mA output proportional to the tank level.

### Ordering data Menkar K 70-76/KM 70-72

order no.	7	M	E	5	8	6	2	-						
<b>Design</b>														
K70/B one site display														1 A
K71/B one site display and touch sensitive switch(es)														1 B
K72/B one site display and integral transducer 4 - 20 mA														1 C
K72/B integral transducer 4 - 20 mA, without one site display														1 D
K76/B touch sensitive switch(es), without one site display														2 A
K77/B integral transducer 4 - 20 mA, without one site display														2 B
KM70/B magnet flapper display														3 A
KM71/B magnet flapper display and touch sensitive switch(es)														3 B
KM72/B magnet flapper display and integral transducer 4 - 20 mA														3 C
<b>connection flange</b>														
DN 20 DIN 2501 PN 40														A
DN 25 DIN 2501 PN 40														B
DN 50 DIN 2501 PN 40														C
speciale connection flange														Z
<b>drain connection</b>														
drain plug														1
drain valve														2
drain flange DN 15 DIN 2501 PN 40														3
drain flange DN 20 DIN 2501 PN 40														4
drain flange DN 25 DIN 2501 PN 40														5
speciale drain connection														9
<b>ventilation</b>														
cap														1
cap with screw plug														2
flange with screw plug														3
flange with ventilation falnge DN 15 PN 40														4
flange with ventilation falnge DN 20 PN 40														5
flange with ventilation falnge DN 25 PN 40														6
speciale ventilation														9
<b>Measuring floats</b>														
in Titanium density 0,40 - 0,500 kg/ dm <sup>3</sup>														1 A
in Titanium density 0,51 - 0,600 kg/ dm <sup>3</sup>														1 B
in Titanium density 0,61 - 0,700 kg/ dm <sup>3</sup>														1 C
in Titanium density 0,71 - 0,795 kg/ dm <sup>3</sup>														1 D
in Titanium density 0,51 - 0,600 kg/ dm <sup>3</sup> pressure relieved														1 E
in Titanium density 0,61 - 0,700 kg/ dm <sup>3</sup> pressure relieved														1 F
in Titanium density 0,71 - 0,795 kg/ dm <sup>3</sup> pressure relieved														1 G
in Titanium density 0,60 - 0,675 kg/ dm <sup>3</sup>														0 2
in Titanium density 0,68 - 0,755 kg/ dm <sup>3</sup>														0 3
in Titanium density 0,76 - 0,835 kg/ dm <sup>3</sup>														0 4
in W.Nr. 1.4571 density 0,85 - 0,950 kg/ dm <sup>3</sup>														0 5
in W.Nr. 1.4571 density 0,96 - 1,150 kg/ dm <sup>3</sup>														0 6
in W.Nr. 1.4571 density 1,16 - 1,295 kg/ dm <sup>3</sup>														0 7
in W.Nr. 1.4571 density 1,20 - 1,500 kg/ dm <sup>3</sup>														0 8
in W.Nr. 1.4571 density 1,00 - 1,150 kg/ dm <sup>3</sup> pressure relieved														6 A
in W.Nr. 1.4571 density 1,16 - 1,295 kg/ dm <sup>3</sup> pressure relieved														7 A
in W.Nr. 1.4571 density 1,20 - 1,500 kg/ dm <sup>3</sup> pressure relieved														8 A
in Titanium density 0,70 - 0,800 kg/ dm <sup>3</sup>														0 0
in Titanium density 0,81 - 0,900 kg/ dm <sup>3</sup>														1 0
in Titanium density 0,91 - 0,795 kg/ dm <sup>3</sup>														1 1
in Glas density 0,60 - 0,750 kg/ dm <sup>3</sup>														1 5
in Glas density 0,76 - 0,1,20 kg/ dm <sup>3</sup>														1 6
in Glas density 0,60 - 0,840 kg/ dm <sup>3</sup> with PTFE cladding														1 7
in Glas density 0,84 - 0,1,20 kg/ dm <sup>3</sup> with PTFE cladding														1 8
in PVC density 0,85 - 0,950 kg/ dm <sup>3</sup>														1 9
in PVC density 0,96 - 1,150 kg/ dm <sup>3</sup>														2 0
in PVC density 1,16 - 1,295 kg/ dm <sup>3</sup>														2 1
in PVC density 1,20 - 1,500 kg/ dm <sup>3</sup>														2 2
in PVDF density 0,85 - 0,950 kg/ dm <sup>3</sup>														2 3
in PVDF für density 0,96 - 1,150 kg/ dm <sup>3</sup>														2 4
in PVDF für density 1,16 - 1,295 kg/ dm <sup>3</sup>														2 5
in PVDF für density 1,20 - 1,500 kg/ dm <sup>3</sup>														2 6
<b>Seal</b>														
KLINGER SIL C 4500														A
Viton														B
<b>contact function</b>														
without contact														0
change over contact K 23														1
contact K 33														2
contact K 33i														3
<b>center distance in mm:</b>														