

Fig. 1 Electromagnetic flow Sensor *mag-flux* MIS 1/D, MIS 2/15 and Flow probe

Application

The magnetic inductive flowmeters *mag-flux* MIS 1/D and *mag-flux* MIS 2/15 are suitable for velocity and flow measurements of nearly all electrically conductive fluids. In addition to the already well-known flowmeters *mag-flux* A, *mag-flux* S and *mag-flux* F5, they offer a well-priced option to your flow measuring applications.

Due to the constant magnetic field, the sensors *mag-flux* MIS 1/D and *mag-flux* MIS 2/15 can be used for medium flow rates up to 3 m/s or 10 m/s (9.84 ft/s or 32.8 ft/s) respectively and a conductivity as low as 20 $\mu\text{S}/\text{cm}$. Temperature, pressure, density and viscosity do not affect the result of the measurement.

The complete measuring device comprises at least one magnetic inductive sensor and a dedicated transmitter. The units work on the principle of Faraday's law of induction, whereby, simply stated, voltage is induced to a conductor which is moving through a magnetic field.

The magnetic inductive sensors *mag-flux* MIS 1/D and *mag-flux* MIS 2/15 are applied mainly in the following industries:

- Water and sewage plants
- Steel industry
- Energy industry, public utilities

Connection and Operation

The sensors work based on the magnetic inductive measuring principle. They are delivered as fully calibrated units and can be installed and set to measure the flow rate in a particular pipe line, using the respective transducer for constant magnetic field measurements. As in most common measuring devices, the prerequisite here is a minimum conductivity of the medium which is to be measured, in this case of approx. 20 $\mu\text{S}/\text{cm}$

Special features

- Sensors available for nearly all nominal diameters and substances (from DN 200 (8") to DN 2000 (80"))
- Easy installation of the sensors, even in existing pipelines
- Quick replacement, anytime
- Sensors can be installed or replaced even under operating conditions
- Calibrated sensors can be easily stored
- Sensor *mag-flux* MIS 1/D suitable for highly contaminated media
- No moving parts, therefore very low maintenance
- Protection class IP 68/NEMA6 with 5 m (16.4 ft) attached cable
- Use of max. 2 sensors with 1 transmitter
- Economical flow rate measurements for large pipe diameters

Installation guideline for standard sensors

The sensors *mag-flux* MIS 1/D and *mag-flux* MIS 2/15 should be installed in a straight run of a pipe line, both for the inlet path and the outflow zone. Generally speaking, a lateral installation is most appropriate when mounted in the horizontal run of a pipeline. The sensors should be mounted using a fitting aid, which can be ordered separately. This component should be welded into the pipe as follows:

- *mag-flux* MIS 2/15 the center of the measuring channel or
- for sensor *mag-flux* MIS 1/D, the centre of the electrode's surface should be 0.12 x di away from the pipe's inside diameter (di = inner pipe diameter).

Based on hydraulic principles, the median flow velocity is 0.12 x di away from the inner wall of the tube. Independent from the Reynolds' number, this applies – as a good approximation – even within the range of laminar flow.

The supplied fitting aids have markings corresponding with the various inner diameters of a tube. Each fitting aid has 2 spigots, which fit into the recesses of the sensors. The spigots must point in the direction of the flow. This defines the orientation of the sensor. When using sensor *mag-flux* MIS 1/D, the axis of the electrode must be 90° to the axis of the flow; while the measuring channel of the sensor *mag-flux* MIS 2/15 must be positioned in the direction of the flow; this can be verified when checking the labelling during installation (see sensor cover). See also system information *mag-flux*

Note of application

- The operator of these measuring instruments is solely responsible for applicability, proper use and the corrosion resistance of the used materials with respect to the media. It is imperative that the selected materials for the measuring instrument's components which come into contact with the media are suitable for the media selected for this process.
- Before replacing the measuring tubes, ensure no hazardous substances remain in the system and the unit is not pressurised.
- The unit may only be used within the pressure and voltage limits specified in the operating instructions.
- The flowmeter complies with the requirements according to Article 3 Paragraph 3 of the Pressure Equipment Directive 97/23/EC. The most hazardous permissible media are the fluids defined in Group 1.
- Provide a touch guard for surface temperatures of > 70°C. This touch guard must be designed in a way that the max. allowable ambient temperature on the unit is not exceeded.

Electromagnetic flow Sensor *mag-flux* Flowprobes

Technical Data *mag-flux* MIS 1/D

Application field	see page 1
Mode of operation	see page 1
Measuring principle	Pulsed constant field (DC)
Inlet	
Installation and nominal values	DN 500 (20") - DN 1000 (40") DN 1200 (48") - DN 2000 (80")
Measuring accuracy	
Error of measurement (under reference conditions)	± 3 % of the reading from 1 m/s to 5 m/s
Reference conditions	
• Media temperature	25°C ± 5°C
• Ambient temperature	25°C ± 5°C
• Time for warm-up	30 min.
• Installation requirements	<ul style="list-style-type: none"> inlet path > 20 x DN outlet zone > 10 x DN installation vertical to the direction of flow
• Media	clean water, not containing gases or solids
• Electric conductivity	> 200 µS/cm
• Flow profile	Rotation symmetric
Operational conditions	
Operational conditions	see page 1
<u>Operating requirements</u>	
Max. operating pressure	max. 60°C / 140°F
Pressure limits	10 bar/ 145 psi
Protection class	IP 68 / NEMA 6
<u>Requirements on the media</u>	
Media type	clean and contaminated media
Min. conductivity of media	> 20 µS/cm
Flow rate	
• Min. measuring range	0 - 1 m/s
• Max. measuring range	0 - 5 m/s
Specifications	
Design	remote version with attached cable, 5m long
Weight (without fitting aid)	approx. 3 kg
Sensor material	
• Sensor body	PVC
• Electrodes	mat. No. 1.4571 (316Ti)
• gaskets	Perbunan (Buna N)
Material of fitting aid	Steel, stainless steel, PVC, PP

Technical Data *mag-flux* MIS 2/15

Application field	see page 1
Mode of operation	see page 1
Measuring principle	Pulsed constant field (DC)
Inlet	
Installation and nominal values	DN 200 (8") - DN 400 (16") DN 500 (20") - DN 1000 (40")
Accuracy	
Error of measurement (under reference conditions)	± 3 % of the reading From 1 m/s to 10 m/s
Reference conditions	
• Media temperature	25 °C ± 5°C
• Ambient temperature	25 °C ± 5°C
• Time for warm-up	30 min.
• Installation conditions	<ul style="list-style-type: none"> inlet path > 20 x DN outlet zone > 10 x DN installation vertical to the direction of flow
• Media	clean water, not containing gases or solids
• Electric conductivity	> 200 µS/cm
• Flow profile	Rotation symmetric
Operational conditions	
Operational conditions	see page 1
<u>Operating requirements</u>	
Max. operating pressure	max. 100°C / 212°F
Pressure limits	20 bar (290 psi) / to 50°C (122°F) 10 bar (290 psi) / to 50°C (122°F)
Protection class	IP 68 / NEMA 6
<u>Requirements on the media</u>	
Media type	clean and contaminated media
Min. conductivity of media	> 20 µS/cm
Flow rate	
• Min. measuring range	0 - 1 m/s
• Max. measuring range	0 - 10 m/s
Specifications	
Design	remote version with attached cable, 5m long
Weight (without fitting aid)	approx. 1,5 kg
Sensor Material	
• Sensor body	PVDF
• Electrodes	mat. No. 1.4571 (316Ti)
• gaskets	Viton
• Flange cover	mat. No. 1.4571 (316Ti)
Material of fitting aid	Steel, stainless steel, PVC, PP

Electrical Connection

Use the cable ends of the sensor to connect to the transmitter, see diagram in Fig. 2 and Fig. 3. If the sensor's cable is too short, a junction box with 2 separate cables up to max. 30 m (98.4 ft) long, may be used to extend the sensor cable (see also Measurement Requirements).

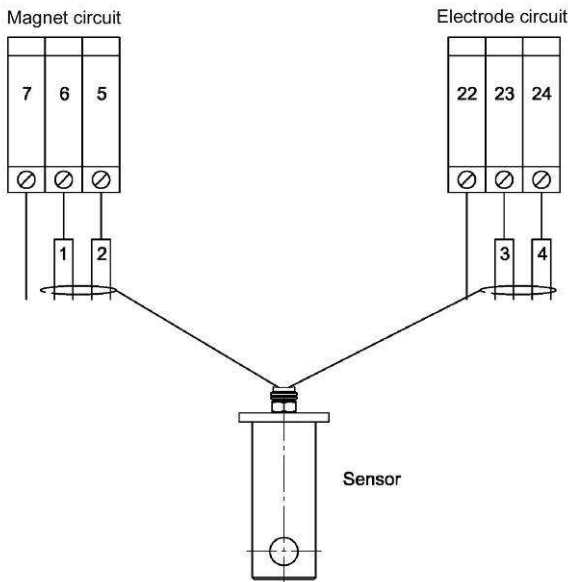

Fig. 2 Electrical connection for one sensor

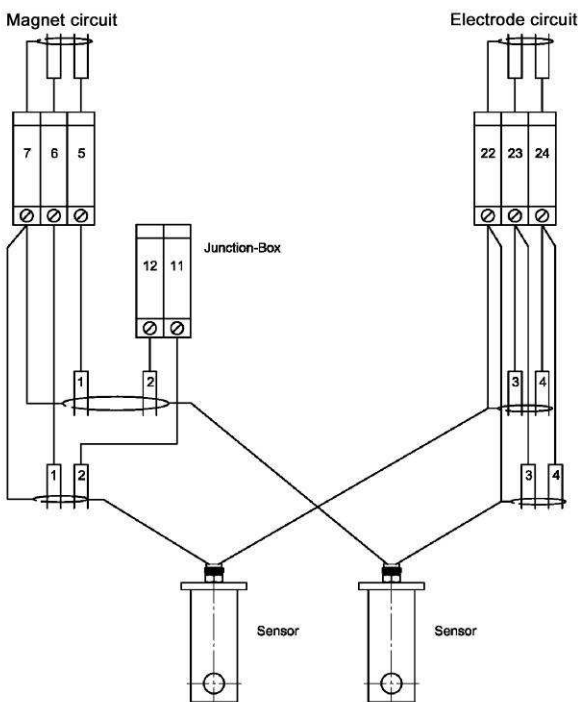

Fig. 3 Electrical connection for two sensors
(Determining the mean value)

Measurement Requirements

In order to maintain the mentioned measurement tolerances, the following prerequisites must be met:

1. Installation of the sensor per instructions.
2. The electrodes of sensor *mag-flux* S1 must be installed exactly vertical to the axis of flow, when using sensor *mag-flux* S2, the measuring channel must be exactly in the direction of the flow.
3. The sensor should be installed in an area of the pipe with a rotation-symmetric flow profile.

Note:

Where the distance of inflow and outflow paths are insufficient, 2 identical sensors may be used to determine the mean value and thereby achieving more accurate measurements. To do this, the sensors must be installed exactly opposite to each other. While using a special junction box, the sensors are connected with the transmitter. The signals are transmitted via two separate shielded cables (magnetic current $2 \times 1.0 \text{ mm}^2$ ($2 \times 0.0016 \text{ in}^2$), electrode current $2 \times 0.5 \text{ mm}^2$ ($2 \times 0.0008 \text{ in}^2$)). We recommend cable type LiYCY.

Recommendation:

When using nominal widths of $> \text{DN } 400$ ($> 16''$), it is recommended to attach 2 sensors opposing each other to the transmitter.

4. All sensor parameters must be fed into the transmitter.
5. Input of the inner pipe diameter into the transmitter.

Measurement Requirements

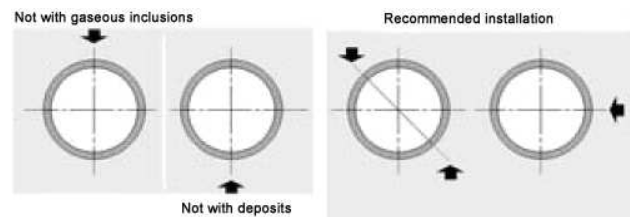

Fig. 4 Installation options

Inlet and Outlet

Ideally, the sensor should be installed in a pipeline with a sufficient straight run, both before and after the measuring point. Experience has shown, that an inflow path of at least 10 to $15 \times \text{DN}$ and an outflow zone of at least 5 to $7 \times \text{DN}$ is required. In extreme cases, e.g. Tee junctions, semi closed valves, or profile turbulences caused by DIN elbows, the inflow distance must be extended (min. approx. $25 \times d_i$, d_i = inner pipe diameter) or a flow conditioner must be installed.

Shortening the Pipeline

If the pipeline must be shortened, ideally, the angle should be $< 8^\circ$. This will avoid the falsification of any measurements and turbulences in the measured area. If the angle is larger than 8° , the inflow and outflow paths must be extended or flow conditioners should be used.

M
S1 und S2

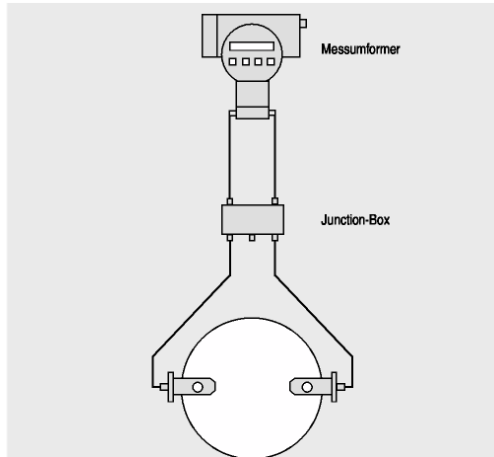

3

Fig. 5 Installation in pipes with large nominal diameters or adverse flow conditions.

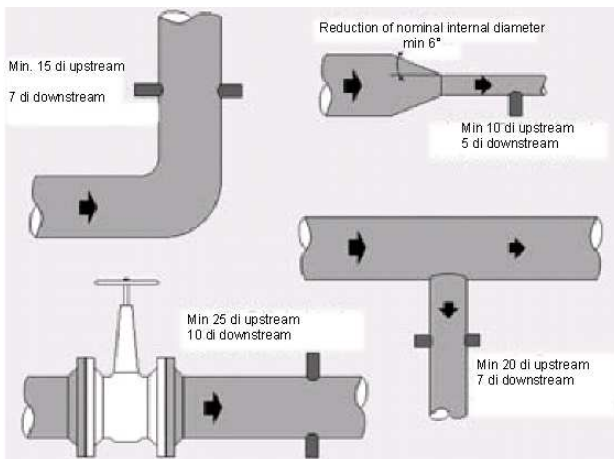

Fig. 6 Installation of 2 sensors if adverse flow profiles exist

Flow profile inside a pipeline

If an asymmetric flow exists inside the measuring tube, the accuracy of the measurement can be maintained by operating up to 2 sensors with one transducer (see Fig. 3). To determine the mean value, the solenoids of the sensor must be connected in series and the electric circuit of the electrodes must be connected in parallel.

When starting up the sensors, ensure the leads 3 (23) and 4 (24) are connected to clamp 23 and 24, and the respective transmitter indicates a positive flow.

Converting the sensor's constant when operating 2 sensors

If 2 sensors are used with one transmitter, a new combined sensor constant must be calculated first by using the individual sensor constants (CFH or C1 value). To do this, both sensor constants must be added and subsequently divided by a factor of 2. The result of this new sensor constant must then be entered into the transmitter.

Start-up

- Follow the diagram on how to connect the sensor with the transmitter.
- Follow the diagram on how to connect the transmitter with the mains power supply. Please observe the instructions applicable to the respective transmitter.
- Switch on the power and fill the pipeline with the respective medium.
- Enter the sensor's constant values CFH and ZPH or C1 into the transmitter.
- Enter the nominal diameter and the final value of the measurement area into the transmitter.
- The device is operational and displays the mean flow velocity or the flow rate inside the pipe.
- If the display indicates a negative value, the leads 3 and 4 (clamp 23 and 24) must be exchanged.

Inspecting the sensor

- When the sensor is removed and is in clean condition, the following electrical characteristics should be displayed:
- Resistance of the solenoid (between leads 1 and 2) approx. 8 to 20 Ω .
- Through-connection of all shielded cables with the sensor's ground.
- Through-connection of the electrodes to the respective lead ends (lead 3 and 4).
- Insulation resistance between the wiring of the electrode and the solenoid approx. 10 to 20 M Ω .
- Insulation resistance between the wiring of electrodes 3 and 4 approx. 10 to 20 M Ω .
- Insulation resistance between the wiring of the electrode or the solenoid against the screen 10 to 20 M Ω .

mag-flux MIS 1/D

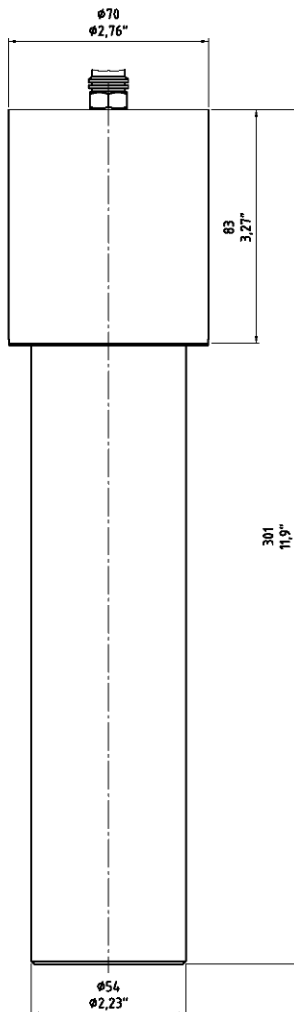

Fig. 6 Sensor *mag-flux* MIS 1/D

Important installation instructions

In order to display the accurate flow rate, it is imperative that the sensor's constant (see rating plate of the sensor) is entered into the transducer.

In general, it must be ensured during the installation as well as when parameterizing the transducer that the inner diameter is used or input.

The fitting aid for sensor *mag-flux* MIS 1/D must be installed in the pipeline in such a fashion as to ensure the centre of the measuring channel is 0.12 x di away from the pipe's inner wall. (di = inner pipe diameter)

When using 2 sensors, the sensors must be installed opposite from each other (see Fig. 4).

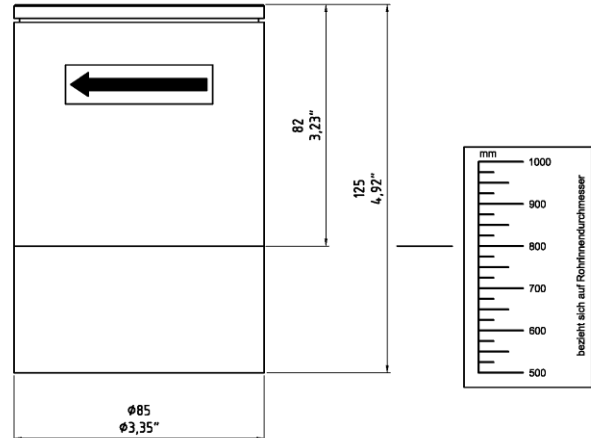

Fig. 7 Fitting aid *mag-flux* MIS 1/D for DN 200/8" up to DN 400/16"; scale displays inner diameter of pipe

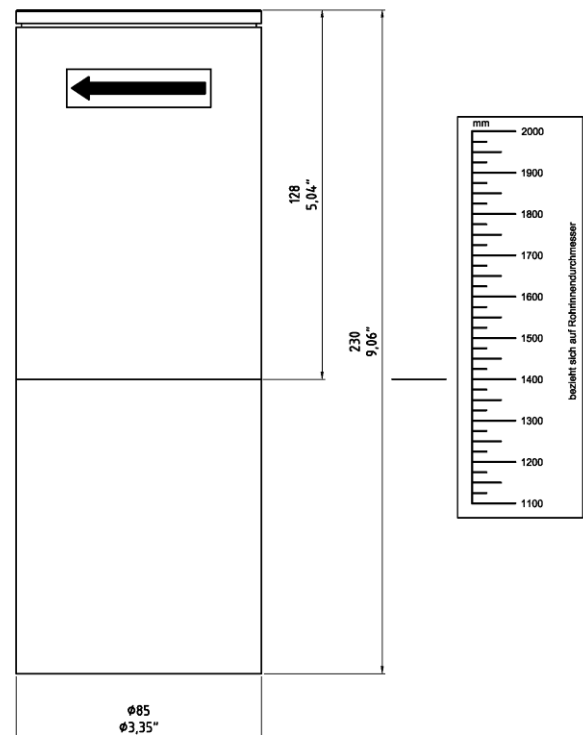

Fig. 8 Fitting aid *mag-flux* MIS 1/D for DN 1100/44" up to DN 2000/80"; scale displays inner diameter of pipe

Earthing

If plastic pipe or tubing with electrical insulation is used, an additional earthing ring bus must be mounted close to the sensor and connected electrically with the transmitter via an earthing cable dia. 4 mm² (0.0062 in²).

If using steel or stainless steel pipes, additional earthing is not necessary. The measuring media is earthed via the pipe.

Dimensions mag-flux MIS 2/15

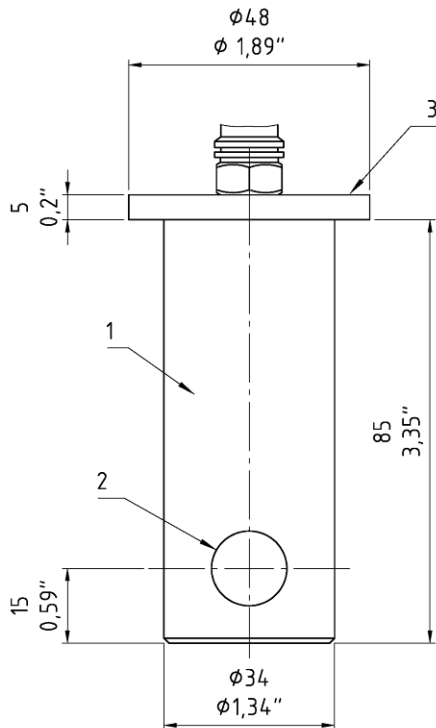

- 1 Sensorkörper PDF
- 2 Sondenkanal $\phi 15\text{mm} / 0,59''$
- 3 Flanschdeckel 1.4571 / 316 Ti

Fig. 9 Sensor mag-flux MIS 1/D

Important installation instructions

In order to display the accurate flow rate, it is imperative that the sensor's constant (see rating plate of the sensor) is entered into the transducer.

In general, it must be ensured during the installation as well as when parameterizing the transmitter that the inner diameter is used or input.

The fitting aid for sensor mag-flux MIS 2/15 must be installed into the pipeline in such a fashion as to ensure the centre of the measurement channel is $0.12 \times di$ away from the pipe's inner wall (di = inner pipe diameter)

When using 2 sensors, the sensors must be installed opposite from each other (see Fig. 4).

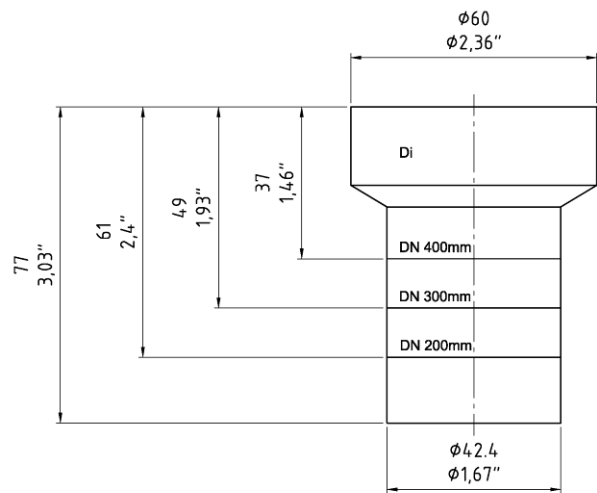

Fig. 10 Fitting aid mag-flux MIS 2/15 for DN 200/8" up to DN 400/16"; scale displays inner diameter of pipe

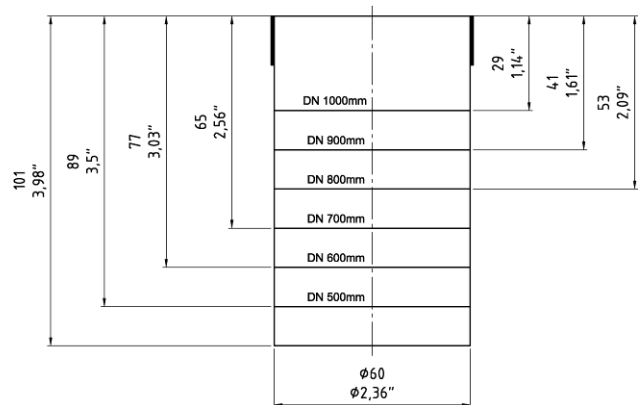

Fig. 11 Fitting aid mag-flux MIS 1/D for DN 500/20" up to DN 1000/40"; scale displays inner diameter of pipe

Earthing

If plastic pipe or tubing with electrical insulation is used, an additional earthing ring bus must be mounted close to the sensor and connected electrically with the transducer via an earthing cable dia. 4 mm² (0.0062 in²).

If using steel or stainless steel pipes, additional earthing is not necessary. The measuring media is earthed via the pipe.

Flow probe



Fig. 12 Sensor *mag-flux* MIS 1/D with changeover tool SMD 3

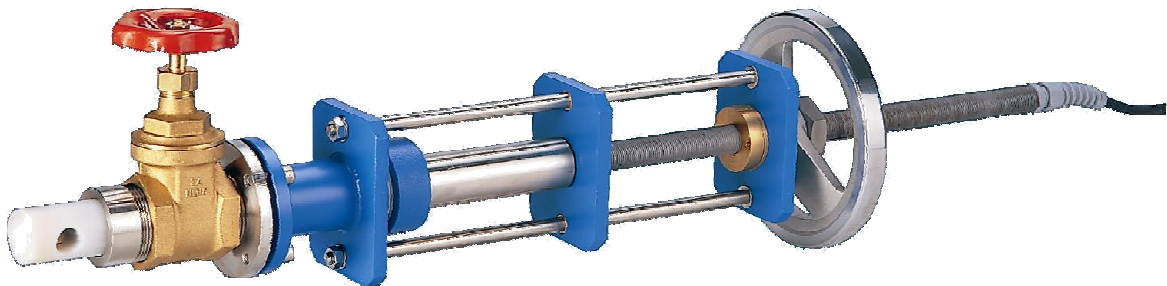

Fig. 13 Sensor *mag-flux* MIS 2/15 with changeover tool SMD2

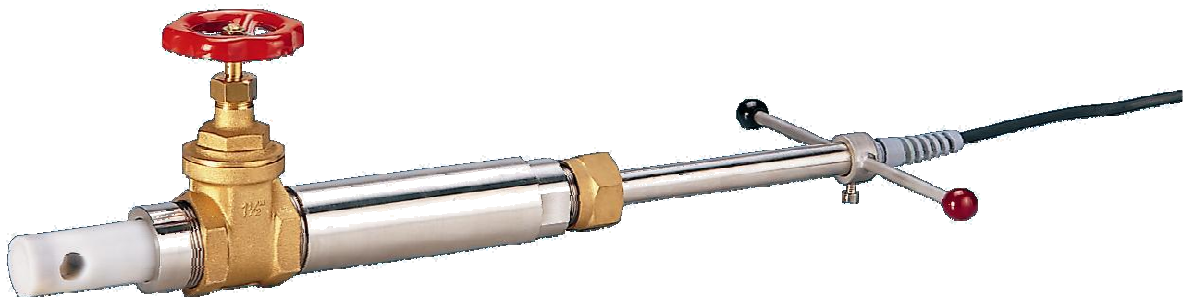

Fig. 14 Sensor *mag-flux* MIS 2/15 Flow-Probe

Electromagnetic flow Sensor *mag-flux* Flowprobes

Ordering data

Electromagnetic flow Sensor *mag-flux* MIS 1/D

MAG5001 -  00 - 0AA0

Material for welded on sockets

- without
- Steel
 - DN 500 - 1000/ 20" - 40" **1 A**
 - DN 1100 - 2000/ 44" - 80" **2 A**
 - DN 2500 /100" **3 A**
- Stainless steel
 - DN 500 - 1000/ 20" - 40" **1 B**
 - DN 1100 - 2000/ 44" - 80" **2 B**
 - DN 2500 /100" **3 B**

Mounting tool with welded on sockets in stainless steel

- without
- sensor tool SMD 3 (for DN 500 - 1000)
- sensor tool SMD 3 (for DN 1000 - 2000)

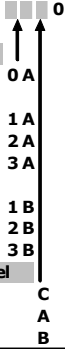

Ordering data

Electromagnetic flow Sensor *mag-flux* MIS 2/15

MAG5002 -  00 - 0AA0

Material for welded on sockets

- without
- Steel
 - DN 100 - 400/ 4" - 16" **1 A**
 - DN 450 - 1000/ 18" - 40" **2 A**
 - DN 1200 - 2000/ 48" - 80" **3 A**
- Stainless steel
 - DN 100 - 400/ 4" - 16" **1 B**
 - DN 450 - 1000/ 18" - 40" **2 B**
 - DN 1200 - 2000/ 48" - 80" **3 B**
- PE
 - DN 100 - 400/ 4" - 16" **1 C**
 - DN 450 - 1000/ 18" - 40" **2 C**
 - DN 1200 - 2000/ 48" - 80" **3 C**
- PVC
 - DN 100 - 400/ 4" - 16" **1 D**
 - DN 450 - 1000/ 18" - 40" **2 D**
 - DN 1200 - 2000/ 48" - 80" **3 D**

Mounting tool

- without
- sensor tool (for max. 2 bar)
- sensor tool (for max. 16 bar)

Flow- Probe

- without
- Length 500 mm
- Length 700 mm
- Length 1000 mm

